

# JVC

# SERVICE MANUAL

COMPACT COMPONENT MD SYSTEM

## NX-MD1R / NX-MD1

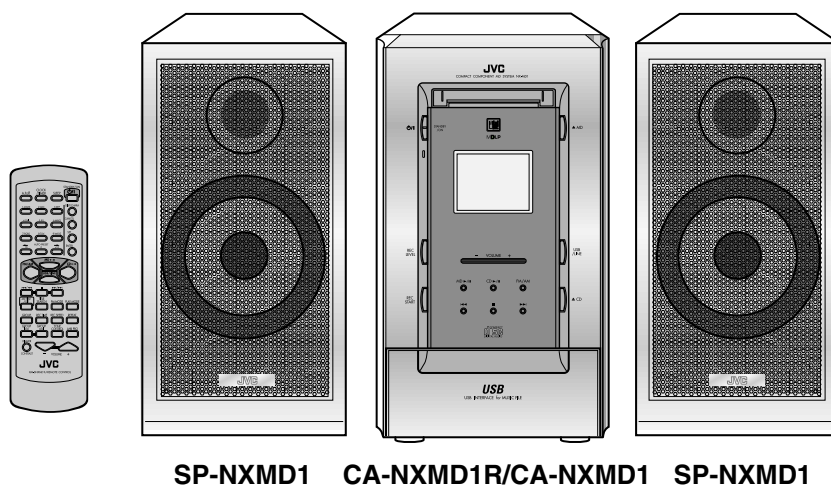

Area suffix [NX-MD1R]	
B .....	U.K.
E .....	Continental Europe
EN .....	Northern Europe

Area suffix [NX-MD1]	
A .....	Australia
US .....	Singapore
UB .....	Hong Kong
UP .....	Korea

SP-NXMD1 CA-NXMD1R/CA-NXMD1 SP-NXMD1

**MDLP**



### Contents

Safety precautions .....	1-2	Flow of functional operation until	
Preventing static electricity .....	1-3	TOC read (MD) .....	1-38
Important for laser products .....	1-5	Maintenance of laser pickup (CD) .....	1-39
Disassembly method .....	1-6	Replacement of laser pickup (CD) .....	1-39
Adjustment method		Maintenance of laser pickup (MD) .....	1-40
(CD/MD section) .....	1-32	Replacement of laser pickup (MD) .....	1-40
Flow of functional operation until		Description of major ICs .....	1-41~68
TOC read (CD) .....	1-37		

## Safety Precautions

1. This design of this product contains special hardware and many circuits and components specially for safety purposes. For continued protection, no changes should be made to the original design unless authorized in writing by the manufacturer. Replacement parts must be identical to those used in the original circuits. Services should be performed by qualified personnel only.
2. Alterations of the design or circuitry of the product should not be made. Any design alterations of the product should not be made. Any design alterations or additions will void the manufacturer's warranty and will further relieve the manufacture of responsibility for personal injury or property damage resulting therefrom.
3. Many electrical and mechanical parts in the products have special safety-related characteristics. These characteristics are often not evident from visual inspection nor can the protection afforded by them necessarily be obtained by using replacement components rated for higher voltage, wattage, etc. Replacement parts which have these special safety characteristics are identified in the Parts List of Service Manual. Electrical components having such features are identified by shading on the schematics and by ( $\triangle$ ) on the Parts List in the Service Manual. The use of a substitute replacement which does not have the same safety characteristics as the recommended replacement parts shown in the Parts List of Service Manual may create shock, fire, or other hazards.
4. The leads in the products are routed and dressed with ties, clamps, tubings, barriers and the like to be separated from live parts, high temperature parts, moving parts and/or sharp edges for the prevention of electric shock and fire hazard. When service is required, the original lead routing and dress should be observed, and it should be confirmed that they have been returned to normal, after re-assembling.
5. Leakage current check (Electrical shock hazard testing)

After re-assembling the product, always perform an isolation check on the exposed metal parts of the product (antenna terminals, knobs, metal cabinet, screw heads, headphone jack, control shafts, etc.) to be sure the product is safe to operate without danger of electrical shock.

Do not use a line isolation transformer during this check.

- Plug the AC line cord directly into the AC outlet. Using a "Leakage Current Tester", measure the leakage current from each exposed metal parts of the cabinet, particularly any exposed metal part having a return path to the chassis, to a known good earth ground. Any leakage current must not exceed 0.5mA AC (r.m.s.).

- Alternate check method

Plug the AC line cord directly into the AC outlet. Use an AC voltmeter having, 1,000 ohms per volt or more sensitivity in the following manner. Connect a  $1,500\ \Omega$  10W resistor paralleled by a  $0.15\ \mu\text{F}$  AC-type capacitor between an exposed metal part and a known good earth ground. Measure the AC voltage across the resistor with the AC voltmeter.

Move the resistor connection to each exposed metal part, particularly any exposed metal part having a return path to the chassis, and measure the AC voltage across the resistor. Now, reverse the plug in the AC outlet and repeat each measurement. Voltage measured any must not exceed 0.75 V AC (r.m.s.). This corresponds to 0.5 mA AC (r.m.s.).

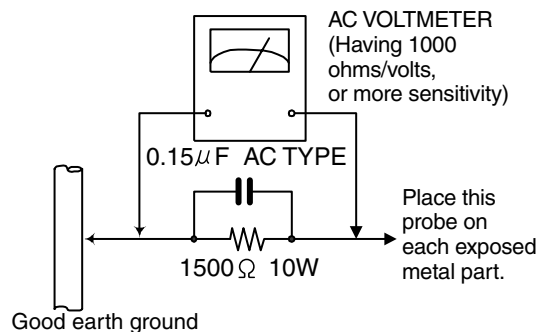

## Warning

1. This equipment has been designed and manufactured to meet international safety standards.
2. It is the legal responsibility of the repairer to ensure that these safety standards are maintained.
3. Repairs must be made in accordance with the relevant safety standards.
4. It is essential that safety critical components are replaced by approved parts.
5. If mains voltage selector is provided, check setting for local voltage.

## CAUTION

**Burrs formed during molding may be left over on some parts of the chassis. Therefore, pay attention to such burrs in the case of performing repair of this system.**

In regard with component parts appearing on the silk-screen printed side (parts side) of the PWB diagrams, the parts that are printed over with black such as the resistor ( $\blacksquare$ ), diode ( $\blacksquare$ ) and ICP ( $\bullet$ ) or identified by the " $\triangle$ " mark nearby are critical for safety.

When replacing them, be sure to use the parts of the same type and rating as specified by the manufacturer. (Excepted the J and C version)

# Preventing static electricity

## 1. Grounding to prevent damage by static electricity

Electrostatic discharge (ESD), which occurs when static electricity stored in the body, fabric, etc. is discharged, can destroy the laser diode in the traverse unit (optical pickup). Take care to prevent this when performing repairs.

## 2. About the earth processing for the destruction prevention by static electricity

Static electricity in the work area can destroy the optical pickup (laser diode) in devices such as CD players. Be careful to use proper grounding in the area where repairs are being performed.

### 2-1 Ground the workbench

Ground the workbench by laying conductive material (such as a conductive sheet) or an iron plate over it before placing the traverse unit (optical pickup) on it.

### 2-2 Ground yourself

Use an anti-static wrist strap to release any static electricity built up in your body.

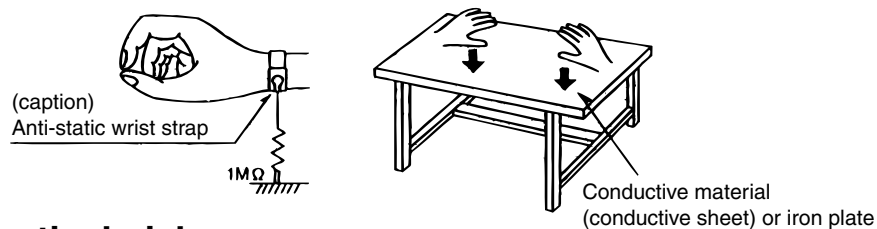

## 3. Handling the optical pickup

1. In order to maintain quality during transport and before installation, both sides of the laser diode on the replacement optical pickup are shorted. After replacement, return the shorted parts to their original condition. (Refer to the text.)
2. Do not use a tester to check the condition of the laser diode in the optical pickup. The tester's internal power source can easily destroy the laser diode.

## 4. Handling the traverse unit (optical pickup)

1. Do not subject the traverse unit (optical pickup) to strong shocks, as it is a sensitive, complex unit.
2. Remove solder of the shorting round on the flexible wire after replacing the optical pickup. For specific details, refer to the replacement procedure in the text. Remove the anti-static pin when replacing the traverse unit. Be careful not to take too long a time when attaching it to the connector.
3. Handle the flexible wire carefully as it may break when subjected to strong force.
4. It is not possible to adjust the semi-fixed resistor that adjusts the laser power. Do not turn it

## 5. Attention when MD traverse unit is decomposed

**\*Please refer to "Disassembly method" in the text for pick-up and how to detach the substrate.**

1. Short the shorting round before the flexible wire is removed from connector CN321 on the MD servo board as shown in Figure.

(When the wire is removed without putting up solder, the MD pick-up assembly might destroy.)

2. Please remove solder after connecting the flexible wire with when you install picking up in the substrate.

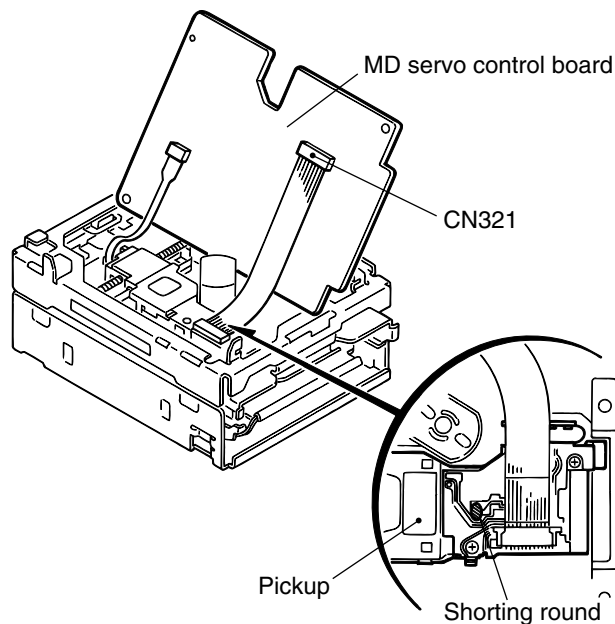

## 6. Attention when CD traverse unit is decomposed

**\*Please refer to "Disassembly method" in the text for pick-up and how to detach the substrate.**

1. Short the shorting round before the flexible wire is removed from connector CN601 on the CD servo board as shown in Figure.

(When the wire is removed without putting up solder, the CD pick-up assembly might destroy.)

2. Please remove solder after connecting the flexible wire with when you install picking up in the substrate.

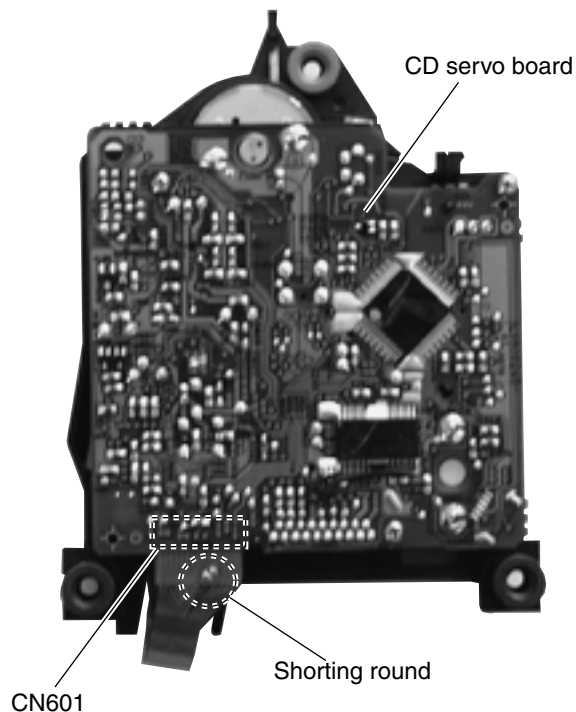

## Important for laser products

### 1.CLASS 1 LASER PRODUCT

**2.DANGER** : Invisible laser radiation when open and inter lock failed or defeated. Avoid direct exposure to beam.

**3.CAUTION** : There are no serviceable parts inside the Laser Unit. Do not disassemble the Laser Unit. Replace the complete Laser Unit if it malfunctions.

**4.CAUTION** : The compact disc player uses invisible laserradiation and is equipped with safety switches which prevent emission of radiation when the drawer is open and the safety interlocks have failed or are defeated. It is dangerous to defeat the safety switches.

**5.CAUTION** : If safety switches malfunction, the laser is able to function.

**6.CAUTION** : Use of controls, adjustments or performance of procedures other than those specified herein may result in hazardous radiation exposure.

 **CAUTION** Please use enough caution not to see the beam directly or touch it in case of an adjustment or operation check.

**VARNING** : Osynlig laserstrålning är denna del är öppnad och spårren är urkopplad. Betrakta ej strålen.

**VARO** : Avattaessa ja suojalukitus ohitettaessa olet alttiina näkymättömälle lasersäteilylle. Älä katso säteeseen.

**ADVARSEL** : Usynlig laserstråling ved åbning , når sikkerhedsafbrydere er ude af funktion. Undgå udsættelse for stråling.

**ADVARSEL** : Usynlig laserstråling ved åbning,når sikkerhetsbryteren er avslott. unngå utsettelse for stråling.

## REPRODUCTION AND POSITION OF LABELS

### WARNING LABEL

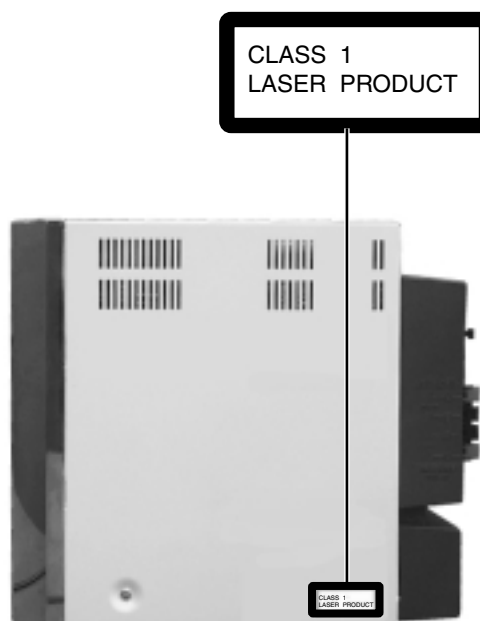

# Disassembly method

## <Main body section>

### ■ Removing the top cover

(See Fig.1 and 2)

1. Remove the four screws **A** attaching the top cover from the back side of the main body.
2. Remove the two screws **B** attaching the top cover from the both sides of the main body.
3. Remove the top cover from the main body while lifting up the back side of the top cover.



Fig.1

### ■ Removing the rear cover (See Fig.3)

• Prior to performing the following procedure, remove the top cover.

1. Remove the nine screws **C** attaching the rear cover from the back side of the main body.
2. Set the speaker and antenna terminals to the locked condition.
3. Disengage the claws **a** of the rear cover from the chassis and remove the cover toward the rear.

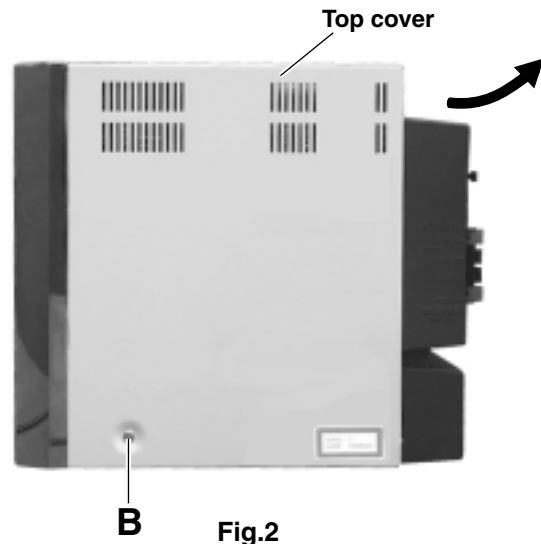

Fig.2

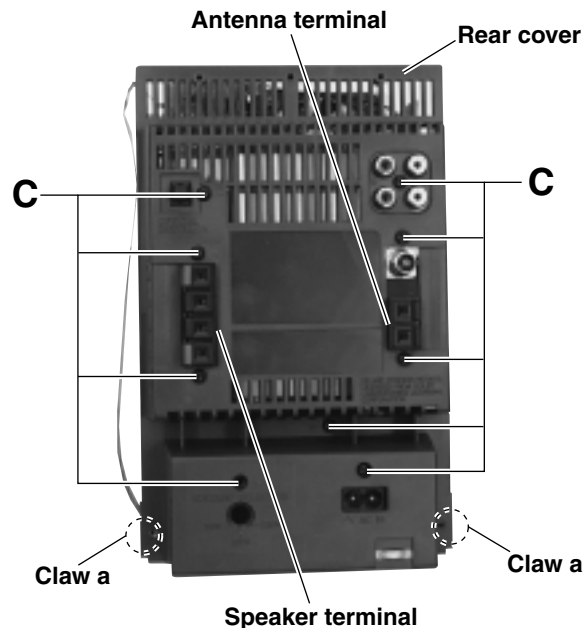

Fig.3

### ■ Removing the system control board (See Fig.4)

- Prior to performing the following procedure, remove the top cover.
  - Prior to performing the following procedure, remove the rear cover.
1. Remove the screw **D** attaching the card wire support board, then remove the card wire support board.
  2. Disconnect the card wires from connectors CN602 and CN605 on the system control board.
  3. Remove the two screws **E** and screw **F** attaching the system control board.
  4. Disconnect connectors CN603 and CN604 on the system control board from the connector CN693 on the regulator board and the CN694 on the repeater board respectively.
  5. Disconnect the wire from connector CN601 on the system control board.

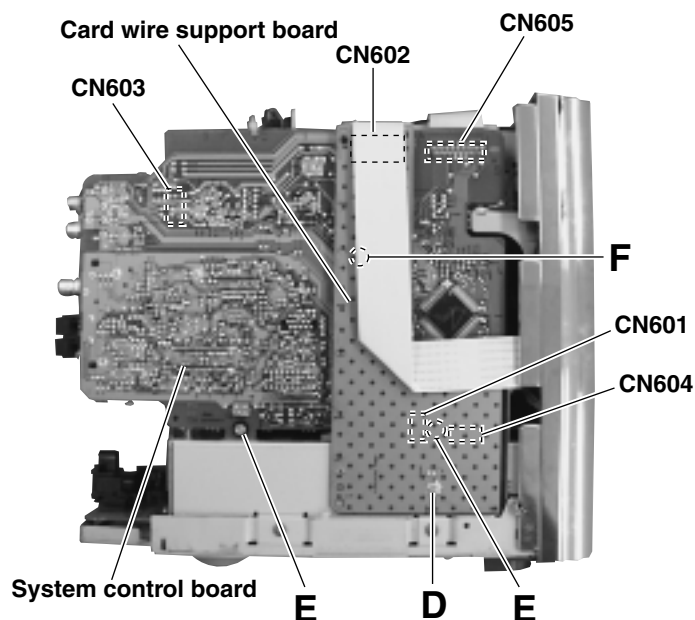

Fig.4

### ■ Removing the main amplifier board (See Fig.5 and 6)

- Prior to performing the following procedure, remove the top cover.
  - Prior to performing the following procedure, remove the rear cover.
1. Disconnect the card wires from connectors CN661, CN695 and CN511 on the main amplifier board.
  2. Remove the protector, then remove the screws **G** attaching the main amplifier board.
  3. Remove the screw **H** and screw **I** attaching the main amplifier board.
  4. Remove the screw **J** attaching the heat sink from the back side.
  5. Disengage claw **b** on the heat sink and disconnect the connectors CN901 and CN904 on the main amplifier board, from connector CN991 on the repeater board and connector CN994 on the regulator board respectively.
  6. Disconnect the wire from connector CN301 on the main amplifier board.

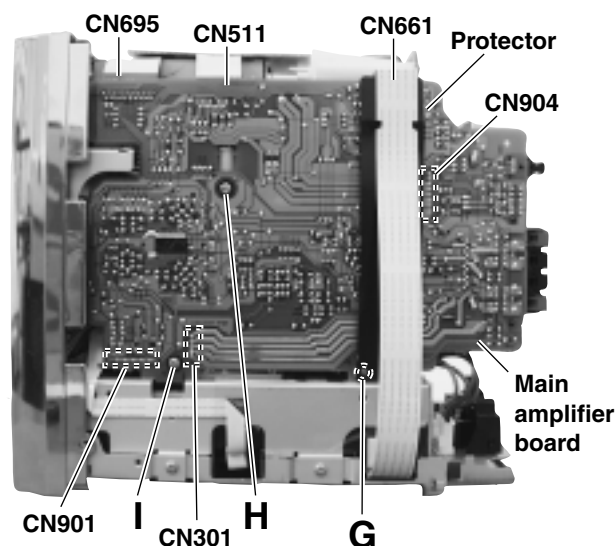

Fig.5

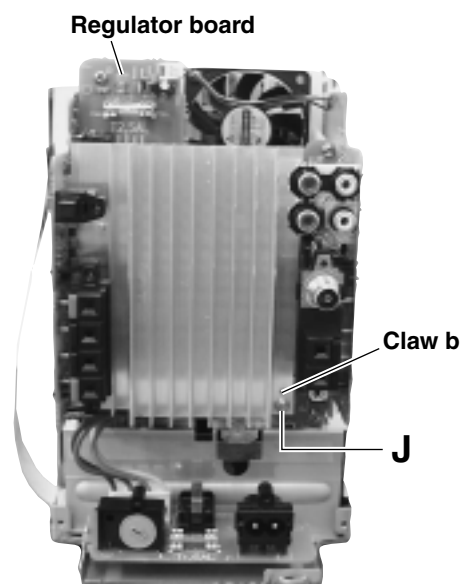

Fig.6

## ■ Removing the regulator board

(See Fig.7)

- Prior to performing the following procedure, remove the top cover.
- Prior to performing the following procedure, remove the rear cover.
- Prior to performing the following procedure, remove the system control board.
- Prior to performing the following procedure, remove the main amplifier board.

1. Remove the two screws **K** and two screws **L** attaching the regulator board.
2. Disconnect the wires from connectors **CN903** and **CN995** on the regulator board.

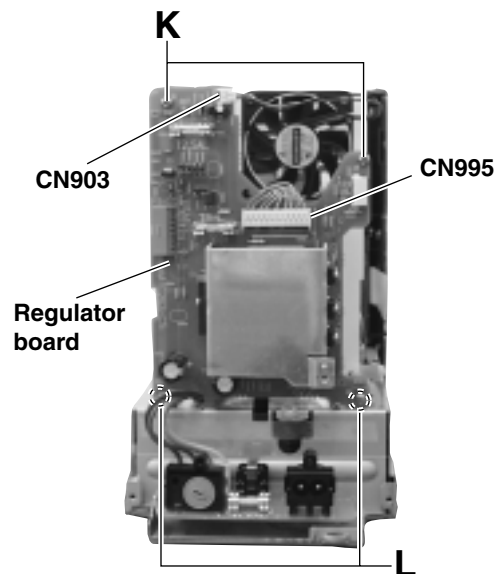

Fig.7

## ■ Removing the AC jack board

(See Fig.8)

- Prior to performing the following procedure, remove the top cover.
- Prior to performing the following procedure, remove the rear cover.
- Prior to performing the following procedure, remove the system control board.
- Prior to performing the following procedure, remove the main amplifier board.
- Prior to performing the following procedure, remove the regulator board.

1. Remove the screw **M** attaching the AC jack board.
2. Disconnect the wire from connector **CN921** on the AC jack board.

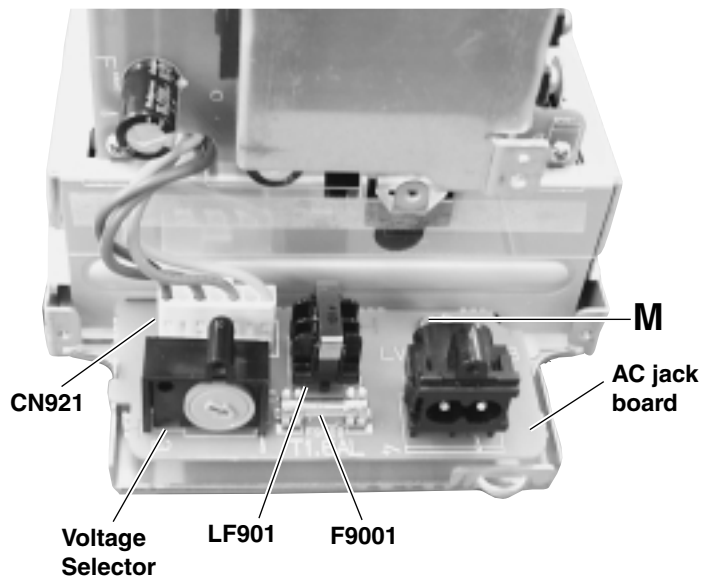

Fig.8



## ■ Removing the MD mechanism assembly (See Fig.9)

- Prior to performing the following procedure, remove the top cover.
- Prior to performing the following procedure, remove the rear cover.
- Prior to performing the following procedure, remove the system control board.
- Prior to performing the following procedure, remove the main amplifier board.

1. Remove the two screws **N** and two screws **P** attaching the MD mechanism assembly.

(Caution) When assembling, attach the screws **N** at the point **c** so that it also fixes the earth wire.

2. Disconnect the card wire from connector CN512 on the repeater board.
3. Disengage the hook **d** from the MD mechanism assembly and lift the rear of the assembly to remove it.

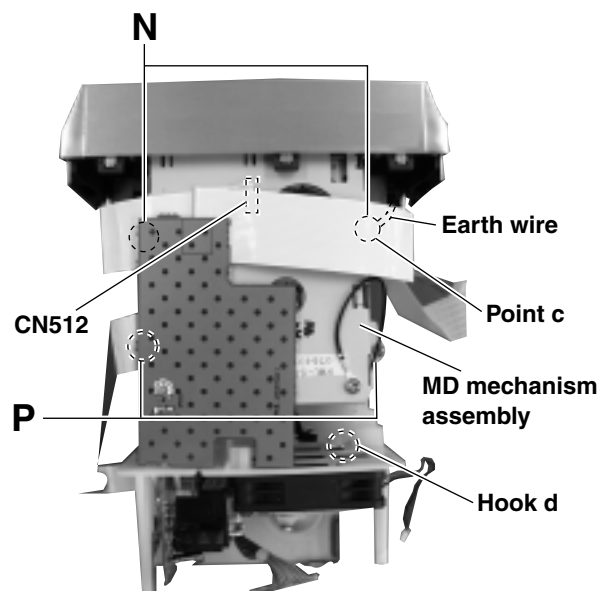

Fig.9

## ■ Removing the fan motor assembly and fan motor (See Fig.10 and 11)

- Prior to performing the following procedure, remove the top cover.
- Prior to performing the following procedure, remove the rear cover.
- Prior to performing the following procedure, remove the system control board.
- Prior to performing the following procedure, remove the main amplifier board.
- Prior to performing the following procedure, remove the regulator board.
- Prior to performing the following procedure, remove the MD mechanism assembly.

1. Remove the four screws **Q** attaching the fan motor assembly from the both sides of the sub chassis.
2. Remove the fan motor assembly to the top side.
3. Remove the two screws **R** attaching the fan motor, then remove the fan motor.

(Caution) When assembling, attach the screws **R** so that they also fix the shield together with the fan motor assembly.

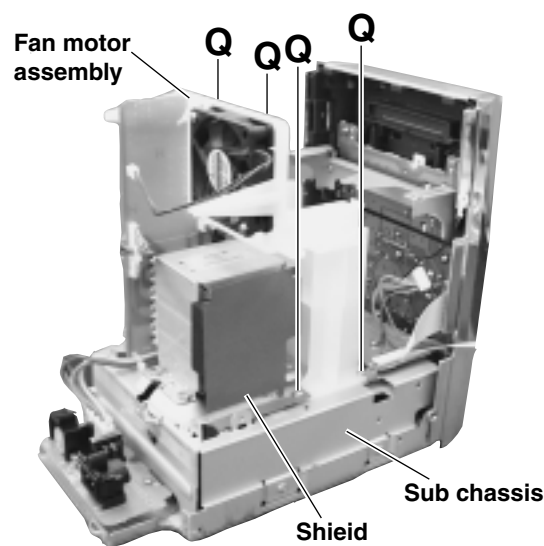

Fig.10

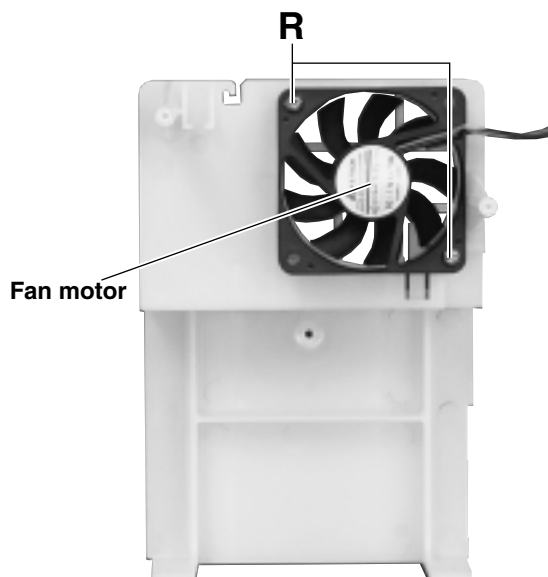

Fig.11

## ■ Removing the power board

(See Fig.12)

- Prior to performing the following procedure, remove the top cover.
- Prior to performing the following procedure, remove the rear cover.
- Prior to performing the following procedure, remove the system control board.
- Prior to performing the following procedure, remove the main amplifier board.
- Prior to performing the following procedure, remove the regulator board.
- Prior to performing the following procedure, remove the MD mechanism assembly.
- Prior to performing the following procedure, remove the fan motor assembly.

1. Remove the four screws **S** attaching the power board from the left and right side of the sub chassis.
2. Disconnect the wire from connector CN921 on the AC jack board.
3. Remove the power board in an upward direction.

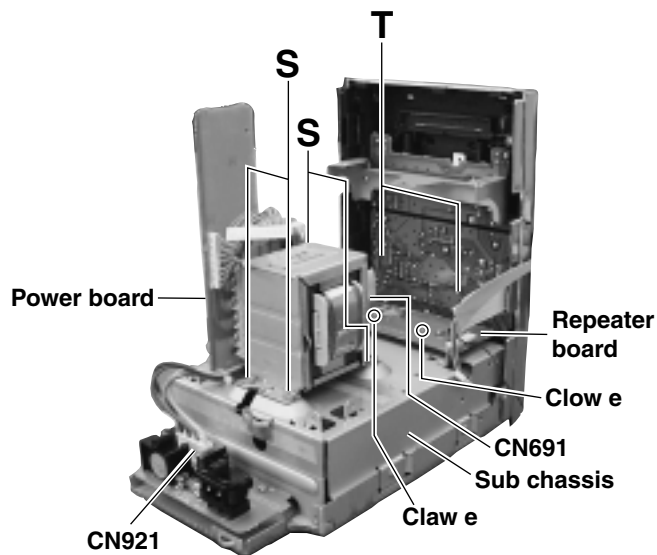

Fig.12

## ■ Removing the repeater board

(See Fig.12)

- Prior to performing the following procedure, remove the top cover.
- Prior to performing the following procedure, remove the rear cover.
- Prior to performing the following procedure, remove the system control board.
- Prior to performing the following procedure, remove the main amplifier board.
- Prior to performing the following procedure, remove the MD mechanism assembly.

1. Remove the two screws **T** attaching the repeater board.
2. Disconnect the card wire from connector CN691 on the repeater board.

(Caution) When assembling, fit the two claws of the sub chassis into the two rectangular holes **e** of the repeater board, before attaching it.

## ■ Removing the CD mechanism assembly (See Fig.13 and 14)

- Prior to performing the following procedure, remove the top cover.
- Prior to performing the following procedure, remove the rear cover.
- Prior to performing the following procedure, remove the system control board.
- Prior to performing the following procedure, remove the main amplifier board.
- Prior to performing the following procedure, remove the AC jack board.
- Prior to performing the following procedure, remove the MD mechanism assembly.

1. Remove the four screws **U** attaching the sub chassis from the left and right side of the bottom chassis.  
Remove the screw **V** attaching the sub chassis.
2. Disconnect the card wire from connector CN691 on the repeater board.
3. Remove sub chassis cover with regulator board and fan motor assembly in the direction of the arrow.
4. Remove the three screws **W** attaching the CD mechanism assembly.
5. Disconnect the card wire from connector CN606 on the CD servo board.
6. Remove the CD mechanism assembly while lifting the rear part of it.

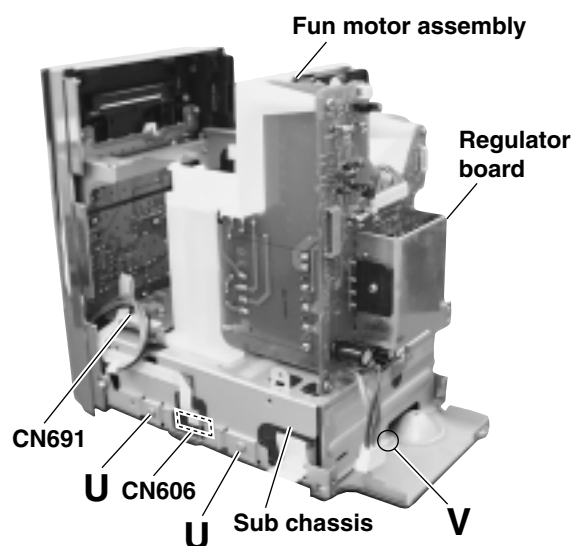

Fig.13

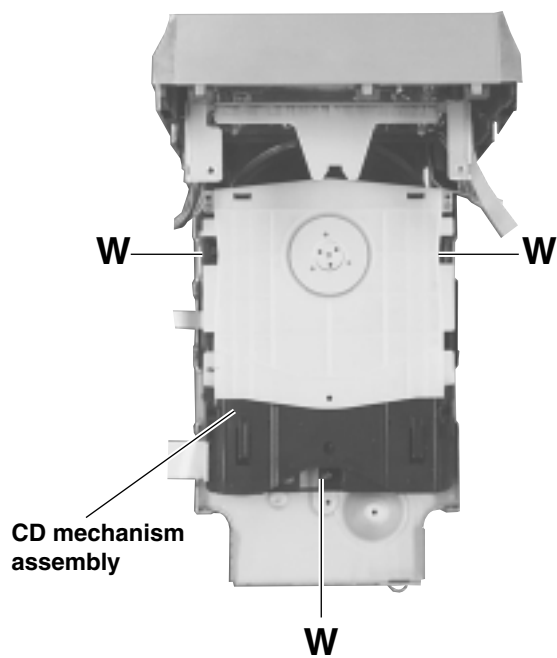

Fig.14

■ **Removing the front panel assembly**  
(See Fig.15)

- Prior to performing the following procedure, remove the top cover.
- Prior to performing the following procedure, remove the rear cover.
- Prior to performing the following procedure, remove the system control board.
- Prior to performing the following procedure, remove the main amplifier board.
- Prior to performing the following procedure, remove the MD mechanism assembly.

1. Remove the two screws **X** attaching the front panel assembly from bottom side of the bottom chassis.

2. Release the three claws **f** on the bottom side of the main body using screwdriver, and detach the front panel assembly toward the front.

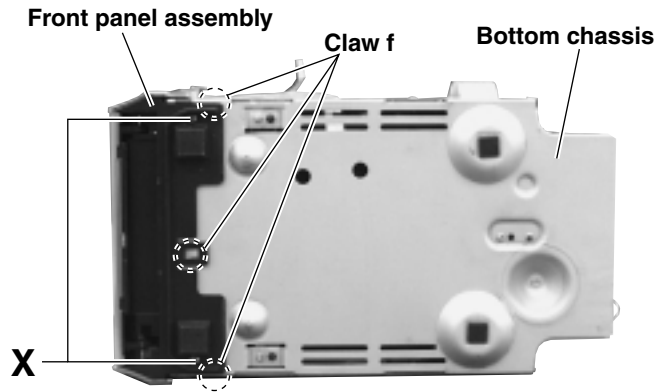

**Fig.15**

## <Front panel assembly section>

- Prior to performing the following procedure, remove the front panel assembly.

### ■ Removing the front board (See Fig.16)

1. Remove the two screws **Y** attaching the MD bracket.
2. Remove the MD bracket.

(Caution) When assembling, fit the rib of the front panel into the location hole **g** on the MD bracket before attaching it.

3. Remove the eight screws **Z** attaching the front board.
4. Remove the front board.

(Caution) When assembling, fit the rib of the front panel into the location hole **h** on the front board before attaching it.

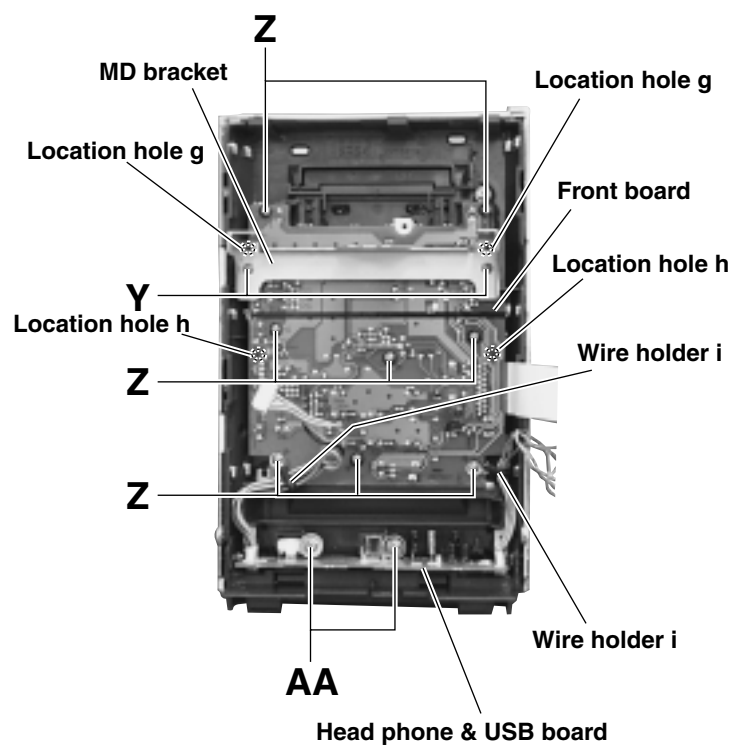

Fig.16

### ■ Removing head phone & USB board (See Fig.16)

1. Remove the wire from two wire holders **i**.
2. Remove the two screws **AA** attaching the head phone & USB board.
3. Remove the head phone & USB board.

## <MD mechanism assembly section>

- Prior to performing the following procedure, remove the top cover.
- Prior to performing the following procedure, remove the rear cover.
- Prior to performing the following procedure, remove the MD mechanism assembly.

### ■ Removing the MD mechanism assembly (See Fig.17)

1. Remove the screw **AB** attaching the earth plate board.
2. Remove the card wire on the MD mechanism assembly.
3. Disconnect the card wire from connector CN522 on the MD servo board, then remove it.
4. Remove the four screws **AC** attaching the MD bracket from left and right side of the MD mechanism assembly.
5. Remove the MD bracket to the bottom side.

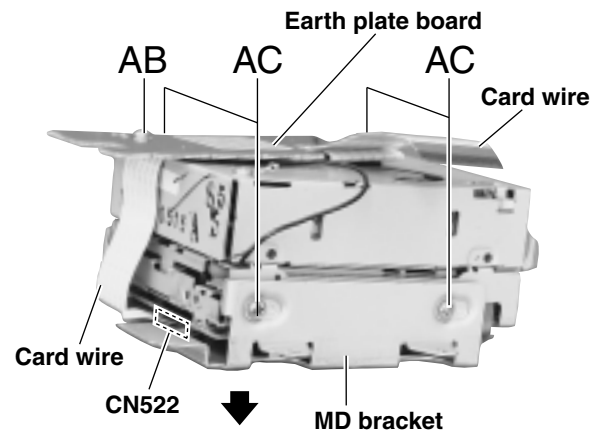

Fig.17

## <Speaker section>

Note : Avoid replacing individual parts.

### ■ Removing the front cover (See Fig.1 to 3)

1. Pull out the saran net toward the front while disengaging the four joints **a**.
2. Insert the tip of a flat-bladed screwdriver or a similar tool into the joints **b** between the main body and the front cover from the bottom of the main body.
3. Lift the front cover little by little to remove.
4. Remove the front cover toward the front and disconnect the yellow and black wires from the two tweeter speaker terminals.

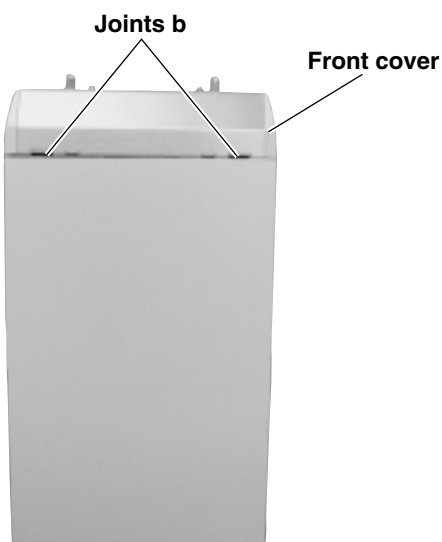
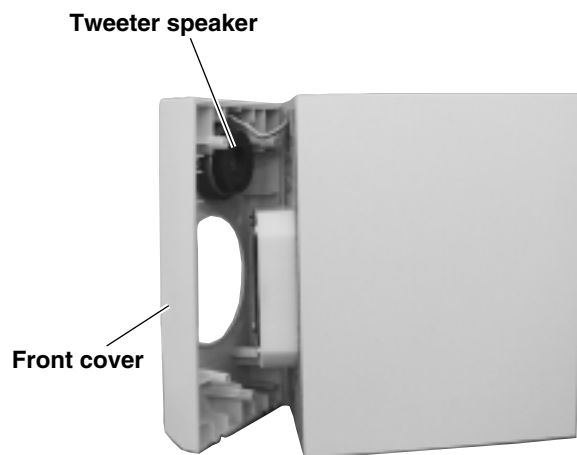

### ■ Removing the woofer speaker (See Fig.4)

• Prior to performing the following procedure, remove the front cover.

1. Remove the four screws **A** on the front of the body.
2. Pull out the woofer speaker toward the front and disconnect the wire (yellow and black, blue and black) from the two speaker terminals.

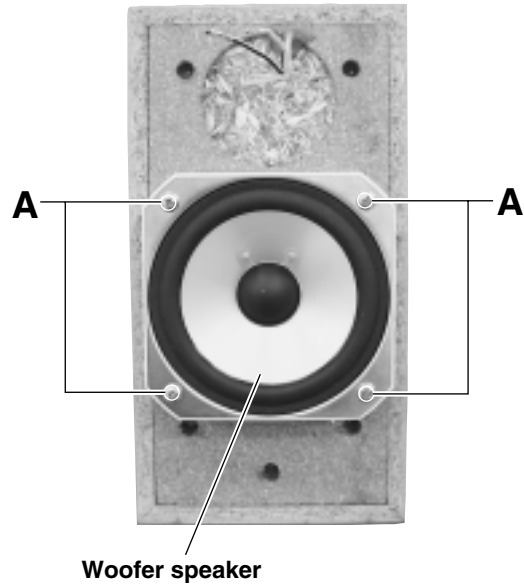

Fig.4

### ■ Removing the tweeter speaker (See Fig.5)

• Prior to performing the following procedure, remove the front cover.

1. Remove the two screws **B** attaching the tweeter speaker on the back of the front cover.

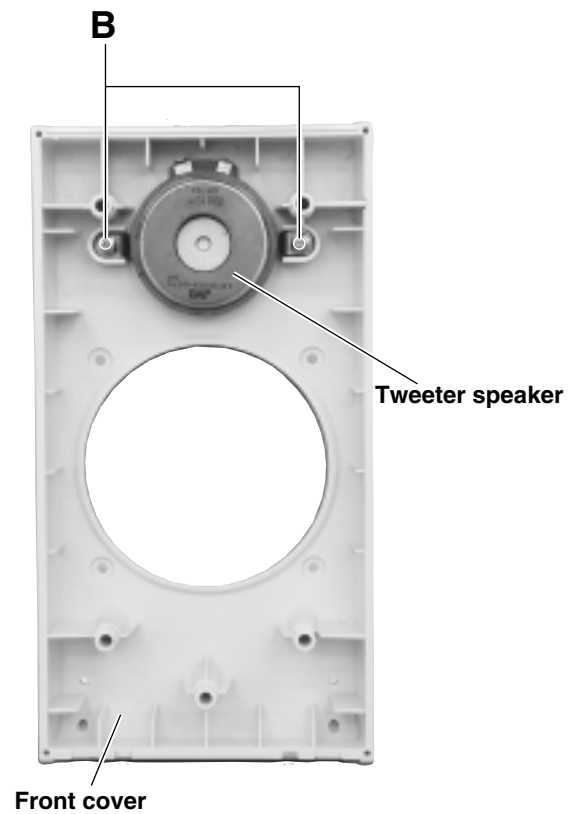

Fig.5



## <CD Mechanism Assembly>

### ■ Removing the CL. Base Assembly and Tray (Refer to Figs. 1 to 5.)

1. Remove the two screws **A** fastening the CL. base assembly from the top of the CD mechanism assembly.
2. Move the CL. base assembly diagonally upwards as indicated by the arrow to release it from the two hooks **a**.
3. Turn the idle gear in the arrow-marked direction from the upper side of the CD mechanism assembly. Accordingly, the TRAMECHA assembly moves downwards.

Note: When drawing out the tray, shift down the TRAMECHA assembly to the position where the tray does not contact the T-T assembly of the TRAMECHA assembly.

4. Draw out the tray frontwards for removing it.

Note: When reinstalling the tray:

- Turn the idle gear so that the part **b** of the tray gear is positioned in the part **c** shown in Fig. 4. (Eject position)
- Engage the right and left hooks **d** and **e** of the tray with the right and left grooves of the TRAMECHA assembly respectively for retaining the tray.

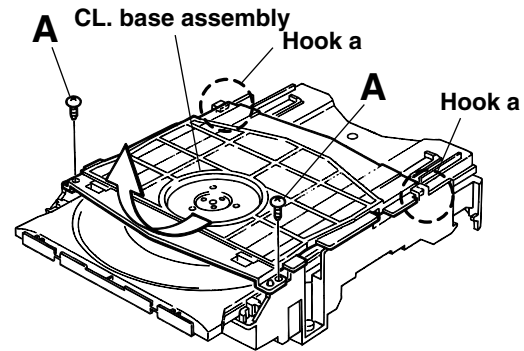

Fig. 1

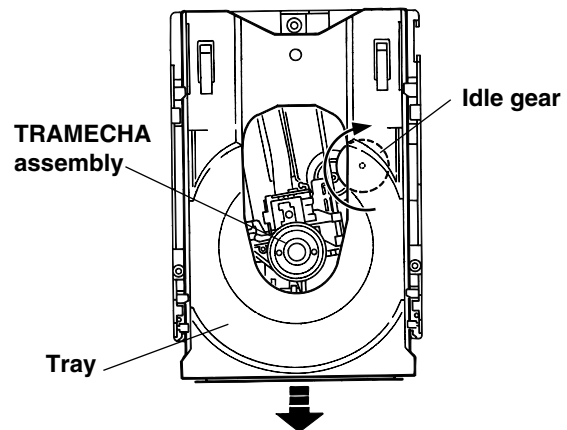

Fig. 2

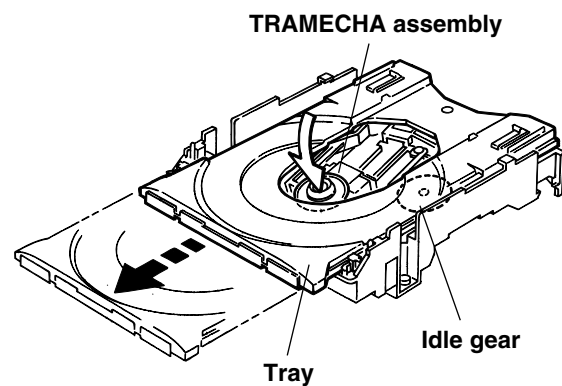

Fig. 3

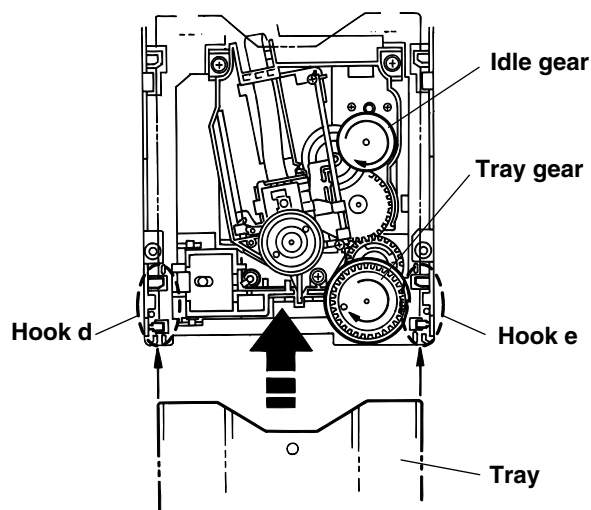

Fig. 5

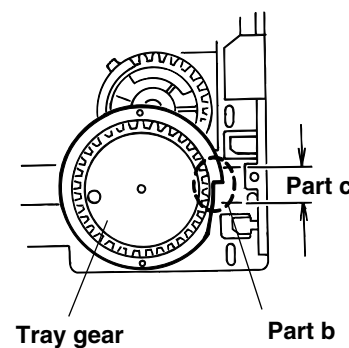

Fig. 4

## ■ Removing the TRAMECHA Assembly (Refer to Figs. 6 to 9.)

- Remove the CL. base assembly and tray.

Reference: The TRAMECHA assembly can be removed without removal of the mechanism P.C. board.

1. If the TRAMECHA assembly is lowered and it is located out of the PLAY position, turn the idle gear in the arrow-marked direction so that the hole in the part **f** of the tray gear meets the hole on the CL. base assembly. (Set the TRAMECHA assembly at the PLAY position.)
2. Remove the three screws **B** fastening the TRAMECHA assembly and then remove the TRAMECHA assembly upwards from the front side.
3. At the same time, remove the spring from the groove of the CH. base assembly in the part **g** of the TRAMECHA assembly.

Note: When reinstalling the TRAMECHA assembly:

- Check to see if the spring is properly engaged with groove of the CH. base assembly in the part **g** of the TRAMECHA assembly.
- After making sure that the three insulators of the TRAMECHA assembly are properly set on the bosses of the L. base assembly's guide, fasten them with the screws.

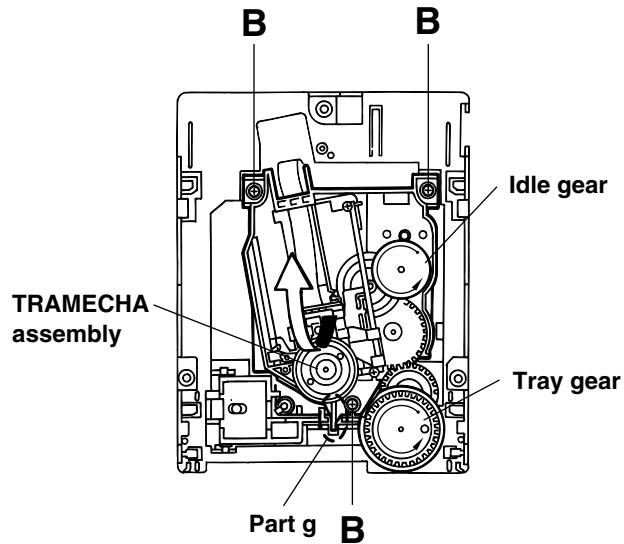

Fig. 6

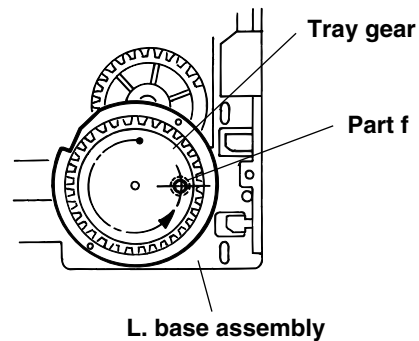

Fig. 7

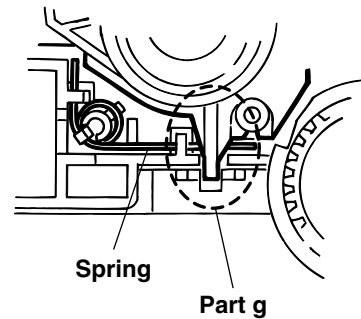

Fig. 8

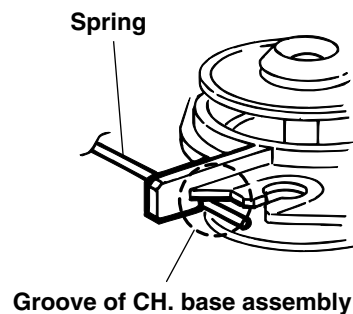

Fig. 9

## ■ Removing the Mechanism P.C. Board (Refer to Fig 10.)

Reference: The mechanism P.C. board can be removed without removal of the TRAMECHA assembly.

Note: Before disconnecting the flexible wire coming from the pickup from the connector, be sure to solder its shorting round. If the flexible wire is connected without soldering, it may cause breakdown of the pickup.

1. Solder the shorting round of the flexible wire connected with the mechanism P.C. board from the back of the mechanism assembly.
2. Disconnect the flexible wire from the connector CN601 on the mechanism P.C. board.
3. Remove the three screws **C** fastening the mechanism P.C. board.
4. Unsolder the two points of the part **h** and one point of the part **i** of the mechanism P.C. board. Then, remove the mechanism P.C. board upwards.

Note: When reinstalling the mechanism P.C. board, connect the flexible wire coming from the pickup to the connector first and then remove the solder from the shorting round of the flexible cable.

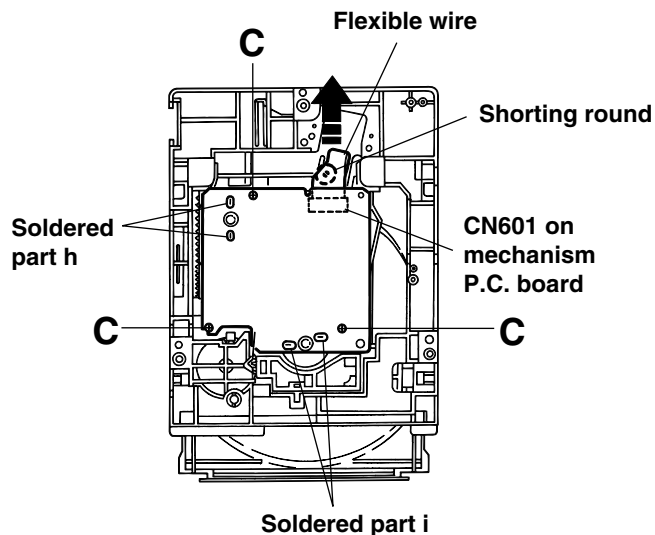

**Fig. 10**

## ■ Removing the Pickup (Refer to Figs. 11 to 14.)

- Remove the CL. base assembly and tray.
- Remove the TRAMECHA assembly.

Reference: The pickup can be removed without removal of the mechanism P.C. board.

Note: Before disconnecting the flexible wire coming from the pickup from the connector, be sure to solder its shorting round.  
If the flexible wire is connected without soldering, it may cause breakdown of the pickup.

1. Solder the shorting round of the flexible wire connected with the mechanism P.C. board from the back of the TRAMECHA assembly.
2. Disconnect the flexible wire from the connector CN601 on the mechanism P.C. board.
3. Turn the idle gear in the arrow-marked direction from the top of the TRAMECHA assembly so that the pickup assembly is shifted to the reverse side of the T-T assembly.  
Move the pickup assembly until the part j of the rack plate in the lower part of the pickup assembly comes out of the CH. base assembly.
4. Remove the two screws **D** retaining the shaft of the pickup assembly. Next, disengage the hook **k** from the CH. base assembly and then remove the pickup assembly together with the shaft.
5. Pull the shaft out of the pickup.
6. Remove the two screws **E** fastening the rack plate from the pickup.
7. Remove the screw **F** retaining the P.S. spring from the pickup.

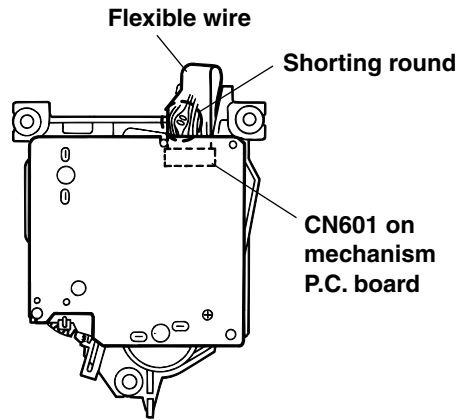

Fig. 11

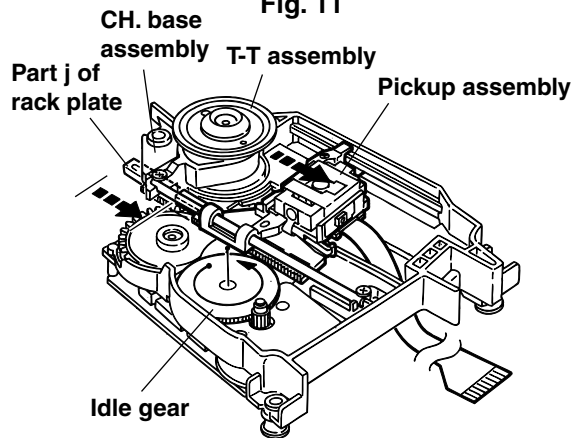

Fig. 12

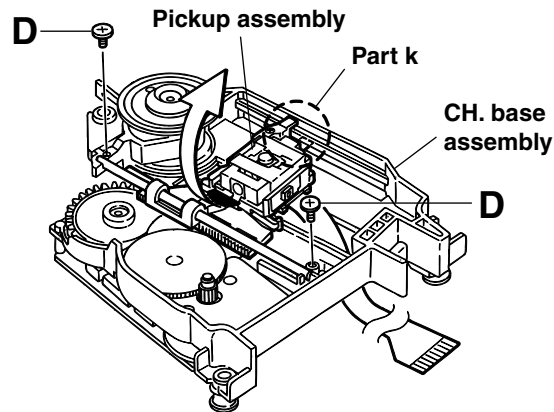

Fig. 13

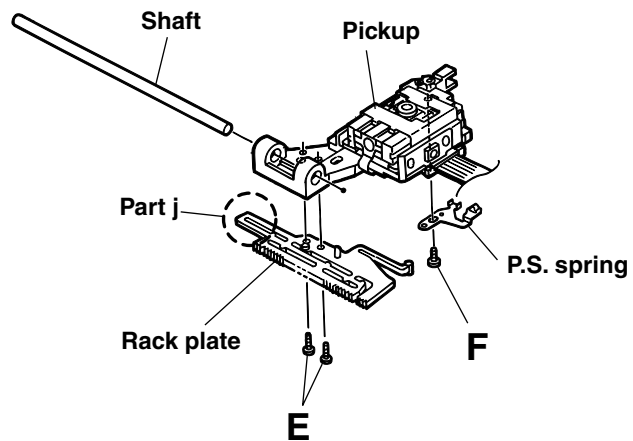

Fig. 14

## ■ Reinstalling the Pickup Assembly (Refer to Figs. 15 and 16.)

Reference: Refer to the explanation of "Removing the Pickup" on the preceding page.

1. Fit the P.S. spring and rack plate to the pickup.
2. Insert the shaft into the pickup.
3. Engage the hook **k** of the pickup assembly with the CH. base assembly first, and set the part **j** of the rack plate in the opening **l** next. Then, reinstall the pickup assembly while shifting it to the T-T side (inward) so that the part **m** of the rack plate is positioned as shown in Fig. 16.
4. Move the pickup assembly to the center position and fasten the shaft with the two screws **D**. (Make sure that the part **n** of the rack plate is correctly engaged with the middle gear.)
5. After passing the flexible wire coming from the pickup through the opening of the CH. base assembly, connect it to the connector CN601.

Note: When reinstalling the pickup assembly, remove the solder from the shorting round after connecting the flexible wire coming from the pick to the connector CN601.

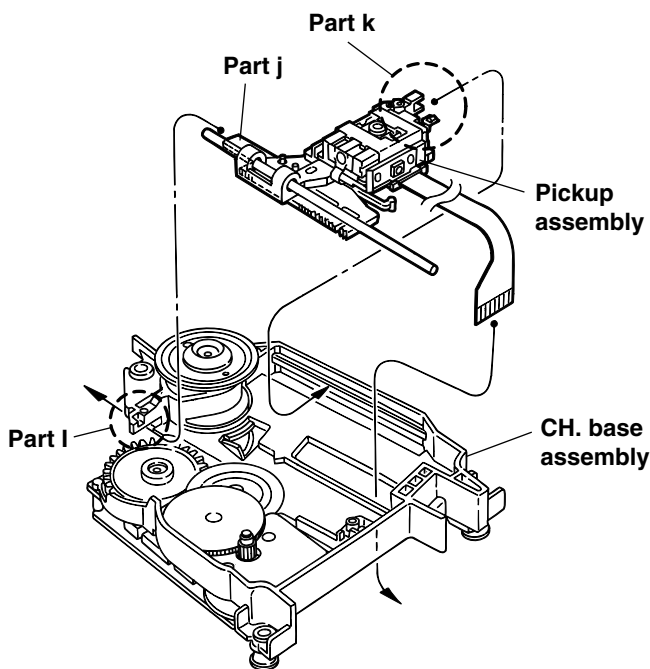

Fig. 15

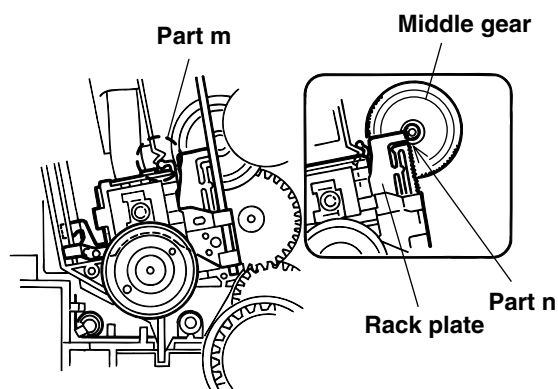

Fig. 16

## ■ Removing the Feed Motor Assembly (Refer to Fig. 17.)

- Remove the CL. base assembly and tray.
- Remove the mechanism P.C. board.

Remove the two screws **G** fastening the feed motor assembly from the top of the mechanism assembly.

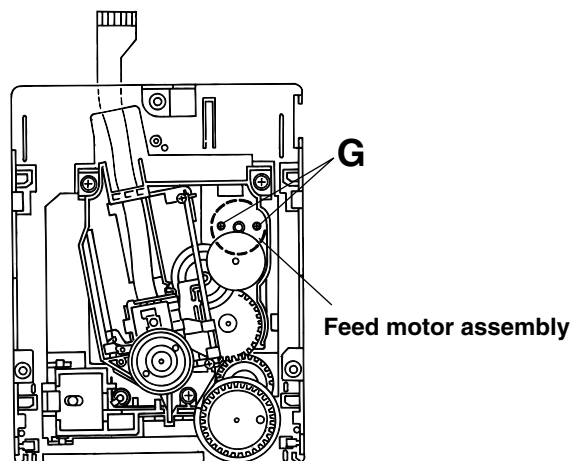

Fig. 17

## <MD mechanism section>

### ■Removing the MD servo board (See Fig.1 and 2)

1. Turn over the body and disconnect the card wires from connectors CN408, CN521 and the flexible wire from CN407 on the MD servo board.
2. Remove the two screws **A** attaching the main board. Slide the MD servo board in the direction of the arrow to release the two joints **a** with the single flame.
3. Shorting round **b** on the pickup in the body. Disconnect the flexible harness from connector CN321 and CN451 on the underside of the MD servo board. Then remove the MD servo board.

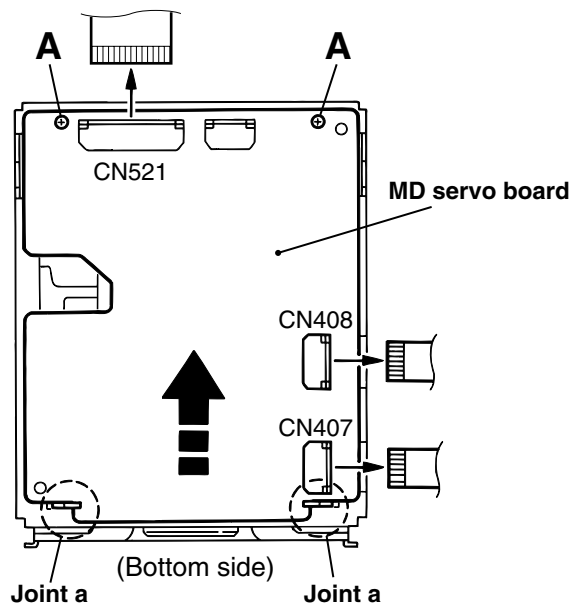

Fig.1

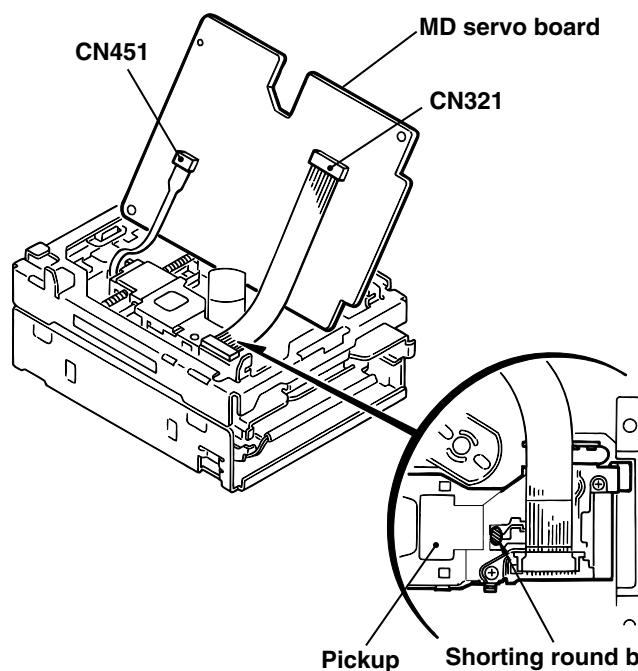

Fig.2

### ■Removing the mechanism cover (See Fig.3)

1. Remove the four screws **B** on both sides of the mechanism cover.
2. Remove the screw **B'** on the earth wire of the mechanism cover.
3. Move the mechanism cover toward the front to disengage the front hook of the mechanism cover from the internal loading assembly (Joint **c**). Then remove the mechanism cover upward.

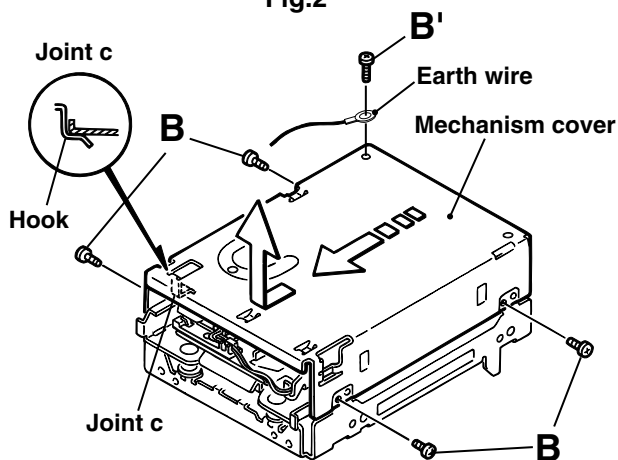
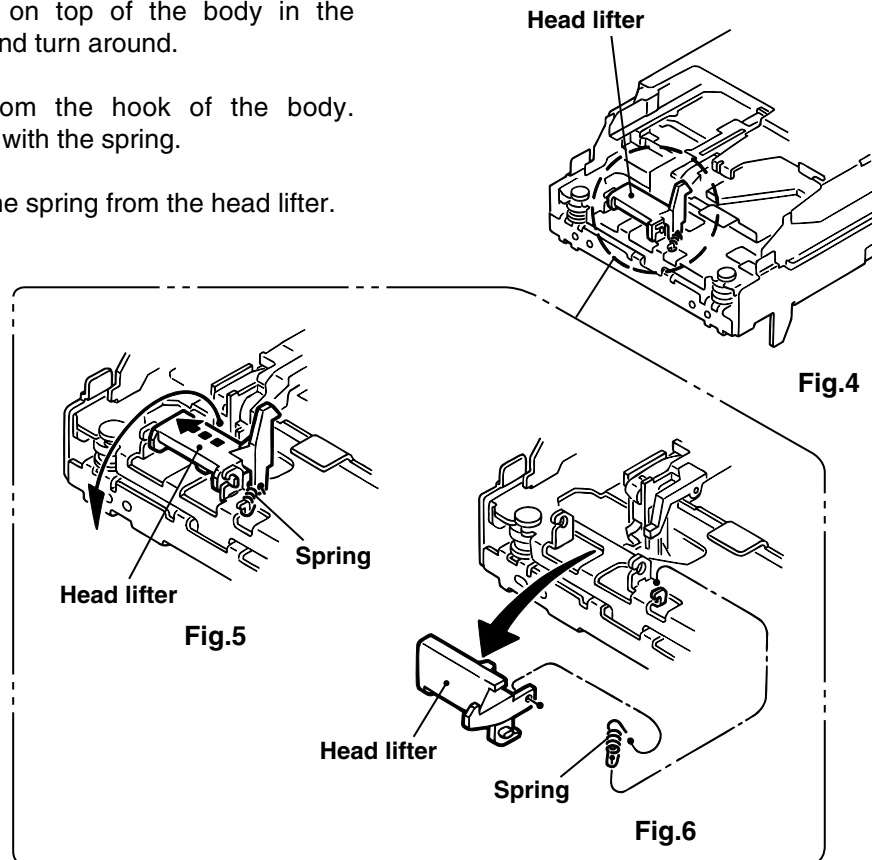

Fig.3

### ■ Removing the head lifter (See Fig.4 to 6)

1. Move the head lifter on top of the body in the direction of the arrow and turn around.
2. Detach the spring from the hook of the body. Remove the head lifter with the spring.
3. If necessary, remove the spring from the head lifter.



### ■ Removing the head assembly (See Fig.7)

1. Remove the screw **C** on the upper side of the body. Remove the head assembly while pulling the flexible harness from the body.

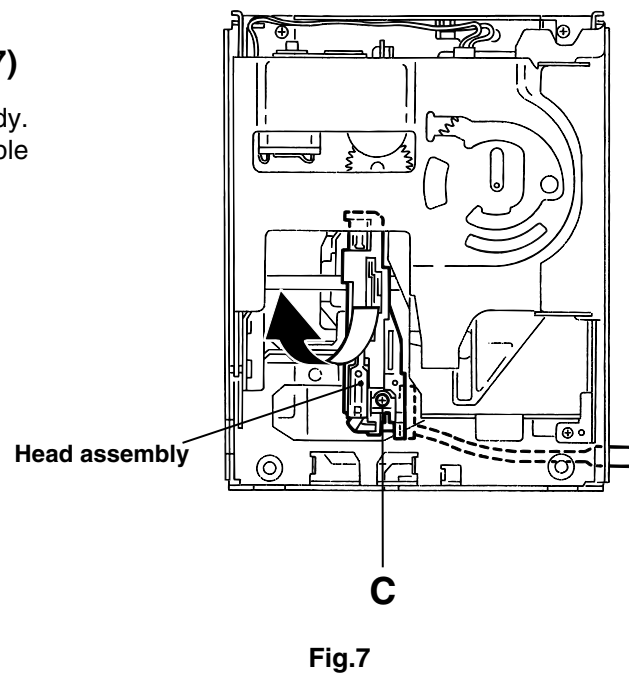

**■Removing the Loading assembly**  
**(See Fig.8 and 9)**

Ref: The loading assembly, the traverse mechanism assembly and the single frame will be removable after removing the loading assembly from the body.

- Prior to performing the following procedure, remove the MD servo board, the mechanism cover, the head lifter and the head assembly.
1. Remove the two screws **D** and screw **D'** on the upper side of the body.
  2. Move the loading assembly forward to disengage it from the traverse mechanism assembly (Joint **d**). Then remove it upward.
  3. Remove the traverse mechanism assembly from the single frame.

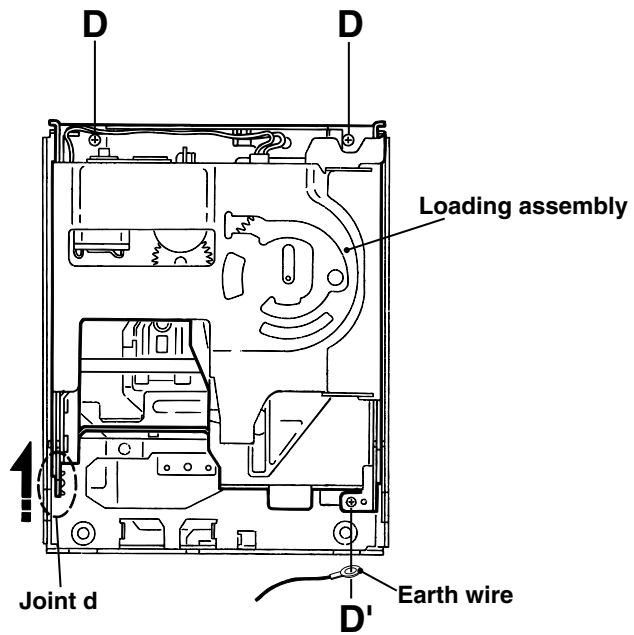

**Fig.8**

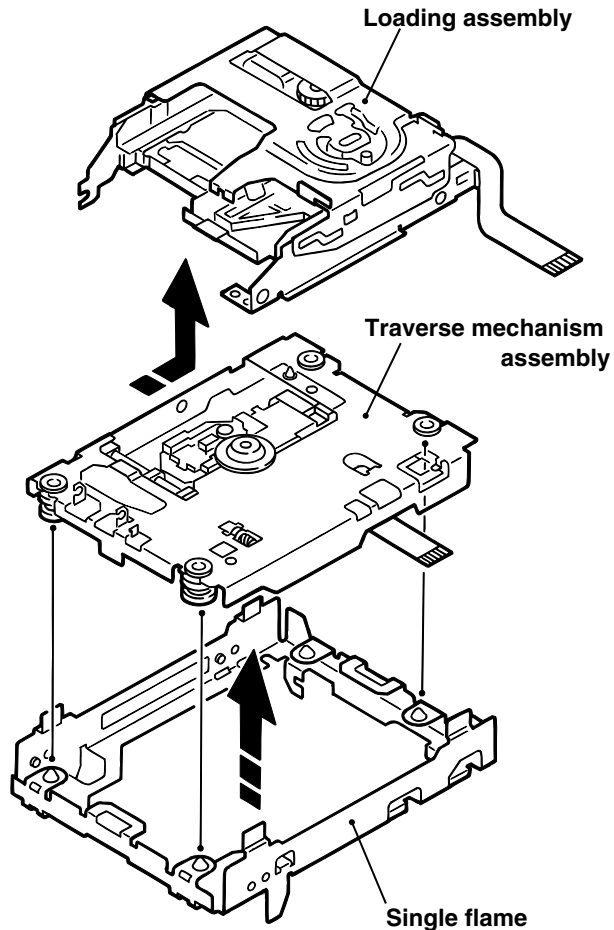

**Fig.9**



## <Loading assembly section>

### ■Removing the slide base (L) / (R)

(See Fig.10)

1. Remove the two screws **E** on the top side of the loading assembly.
2. Remove the slide base (L) outward. (Release it from the joint bosses **e'**.)
3. Remove the slide base (R) outward.

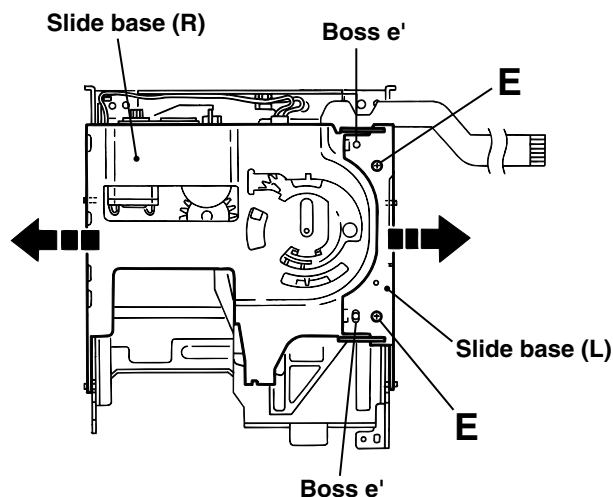
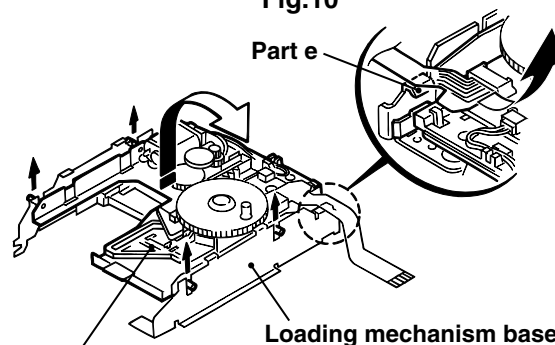

Fig.10

### ■Removing the loading mechanism assembly (See Fig.11)

1. Detach the loading mechanism assembly upward to release the four pins on both sides from the loading motor, paying attention to the part **e** of the loading mechanism base.



Loading mechanism assembly Fig.11

## <Loading mechanism assembly section>

### ■Removing the loading motor

(See Fig.12 and 13)

1. Disconnect the harnesses from the wire holder and from connector CN612 on the cam switch board.
2. Remove the screw **F** attaching the loading motor and release the joint **f**.
3. Remove the belt from the loading motor assembly.
4. Remove the slit washer to the cam gear.
5. Remove the two screws **G** attaching the loading motor.

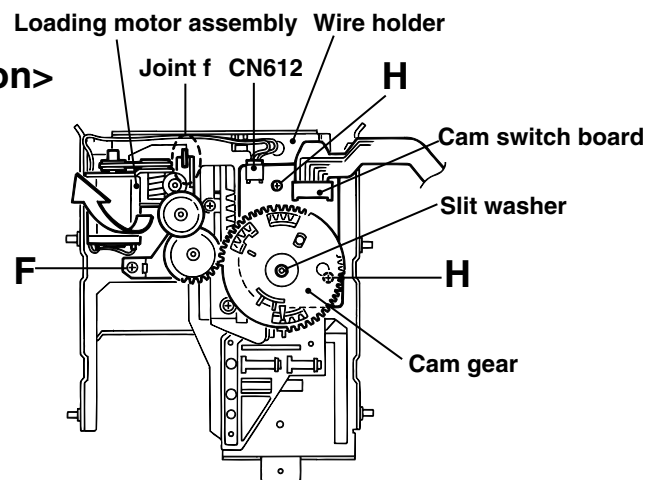

Fig.12

### ■Removing the cam gear and the cam switch board (See Fig.12)

1. Remove the slit washer attaching the cam gear and pull out the cam gear.
2. Disconnect the harness from the wire holder and from connector CN612 on the cam switch board.
3. Remove the two screws **H** and the clamp. Remove the cam switch board.

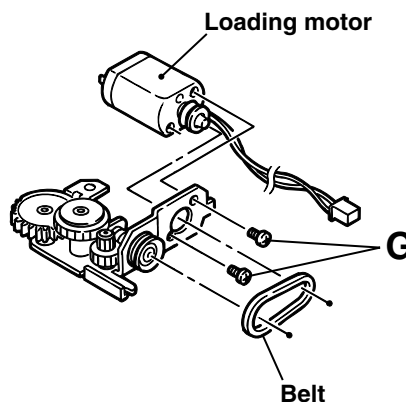

Fig.13

■ **Removing the cartridge holder assembly**  
(See Fig.14 and 15)

1. Remove the two screws **J** on the top side of the loading assembly.

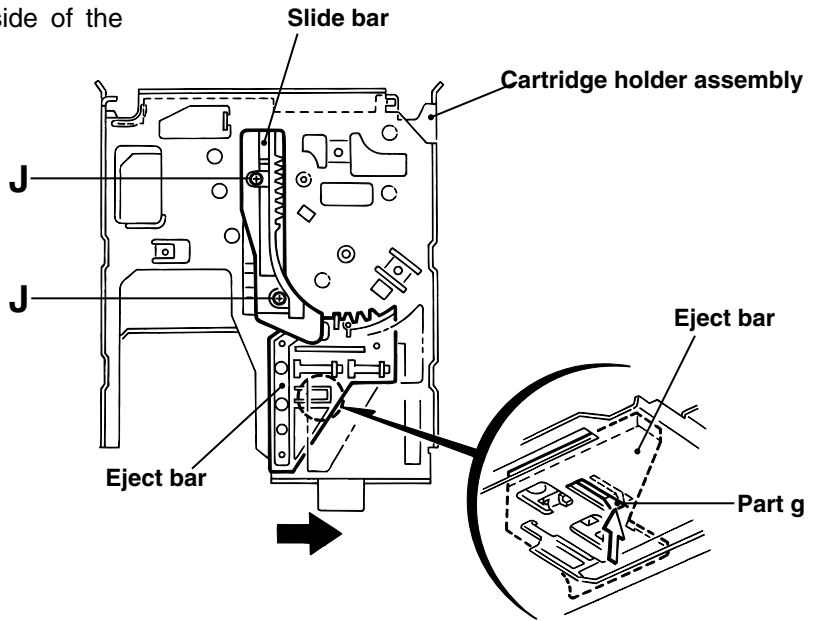

Fig.14

■ **Removing the slide bar and the eject bar**  
(See Fig.14 and 15)

- Prior to performing the following procedure, remove the cartridge holder assembly.
1. Remove the slide bar upward.
  2. Move the eject bar outward until it stops as shown in **Fig.14**. Push the convex part **g** on the bottom of the body and remove the eject bar from the chassis.

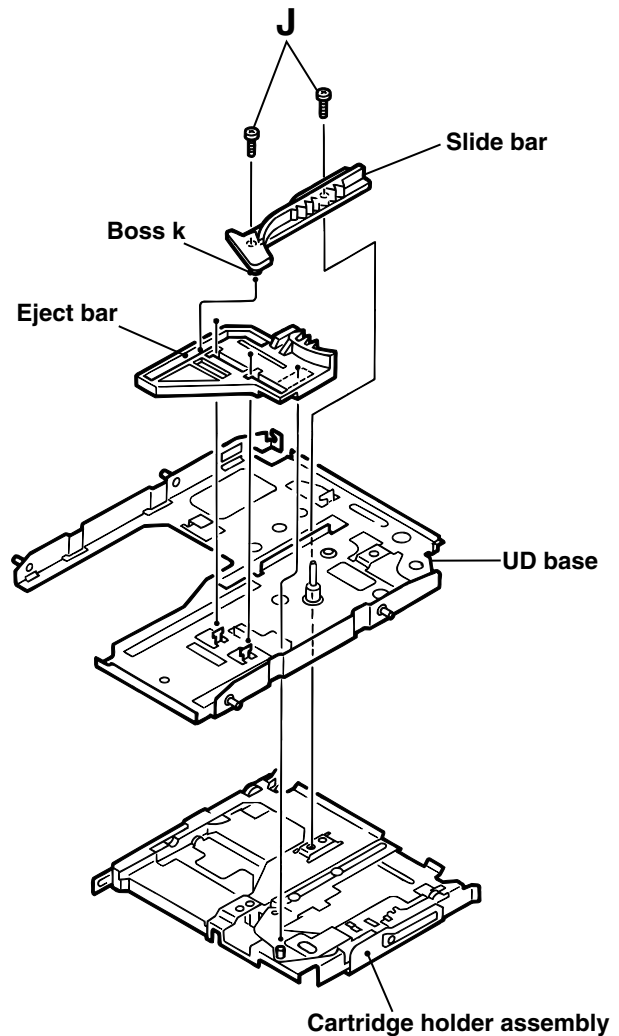

Fig.15

## <Traverse mechanism assembly section>

### ■Removing the Insulators (See Fig.16)

1. Disengage the four insulators from the notches of the traverse mechanism chassis.

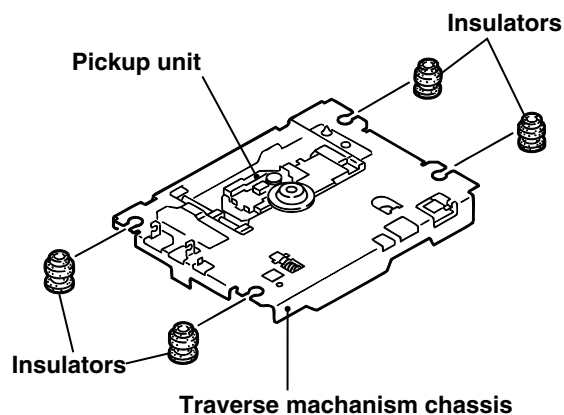

Fig.16

### ■Removing the pickup unit (See Fig.17)

1. Turn over the traverse mechanism assembly and remove the screw **K** attaching the shaft holder (F).
2. Move the shaft inward and remove it from the shaft holder (R).
3. Detach the shaft side of the pickup unit upward and release the joint **h** with the pickup guide. Then remove the pickup unit with the shaft.

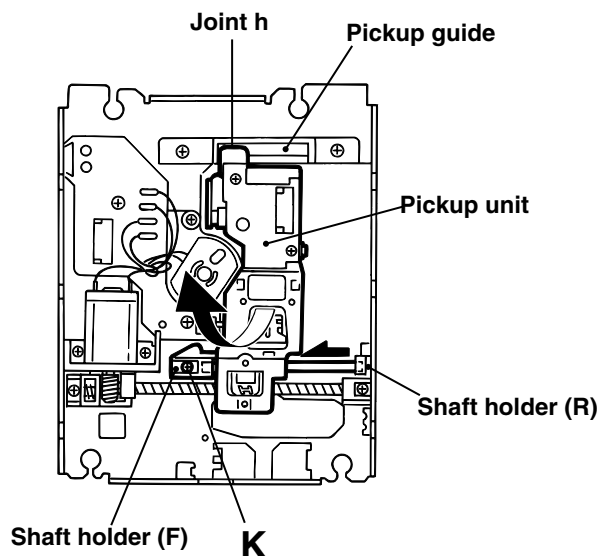

Fig.17

### ■Removing the pickup (See Fig.18)

1. Draw out the shaft from the pickup.
2. Remove the two screws **L** attaching the rack spring.

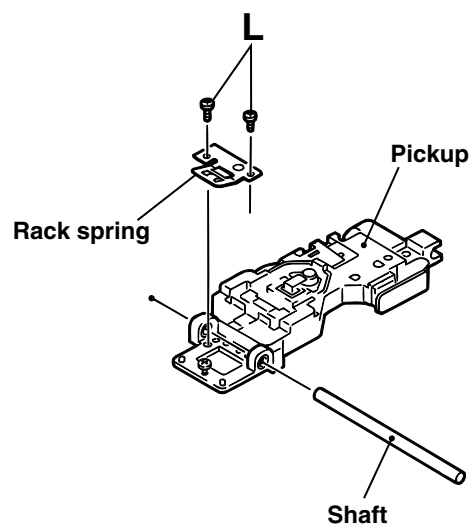
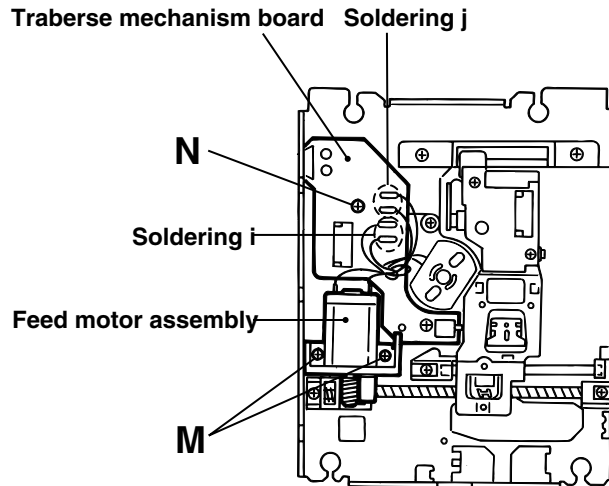

Fig.18

**■Removing the feed motor assembly  
(See Fig.19, 20)**

- It is not necessary to remove the pickup unit.
1. For the white and black harnesses extending from the feed motor assembly, unsolder the soldering **i** on the traverse mechanism board.
  2. Remove the two screws **M** attaching the feed motor assembly.
  3. Remove the two screws **P** attaching the feed motor bracket.



**Fig.19**

**■Removing the traverse mechanism board (See Fig.19)**

- Prior to performing procedure, remove the feed motor assembly.
1. For the red and black harnesses extending from the spindle motor, unsolder the soldering **j** on the traverse mechanism board.
  2. Remove the screw **N** attaching the traverse mechanism board.

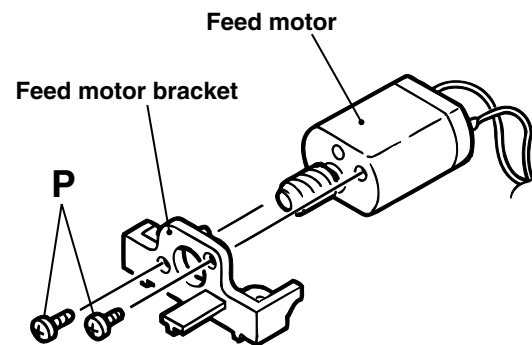

**Fig.20**

### <Reattaching the loading assembly>

1. Reattach the eject bar to the UD base.  
(Fig.15 and 21)
2. Reattach the slide bar to the loading mechanism chassis while fitting the boss marked **k** to the eject bar ditch **k'**. (Fig.21)
3. Slide the slide bar and the eject bar in the direction of the arrow in Fig.21 and reattach the cartridge holder assembly using the two screws **J**.  
(Fig.21 and 22)

ATTENTION: Make sure the pin of the eject lever marked **m** is fitted to the slot of the eject bar marked **n** at the bottom of the loading mechanism chassis after moving the eject lever and the loading slider of the cartridge holder assembly in the direction of the arrow.

(Refer to Fig.22)

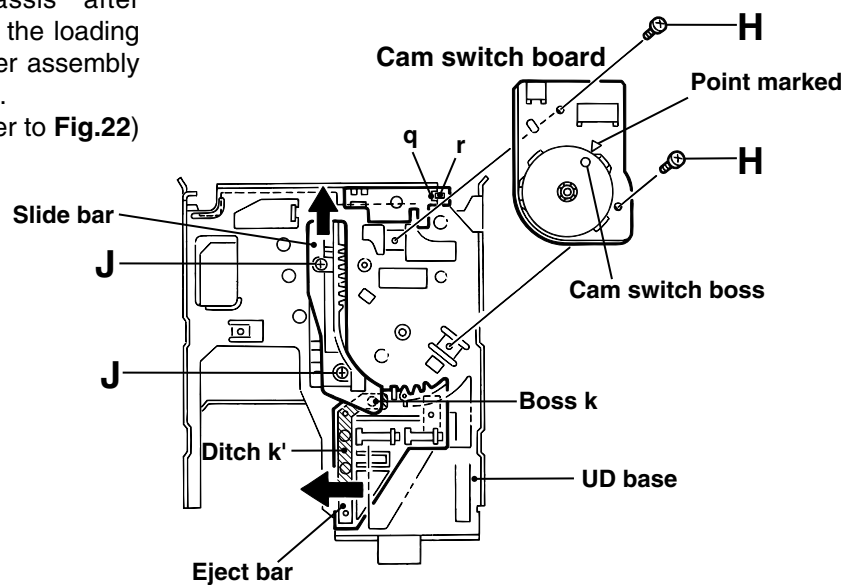

Fig.21

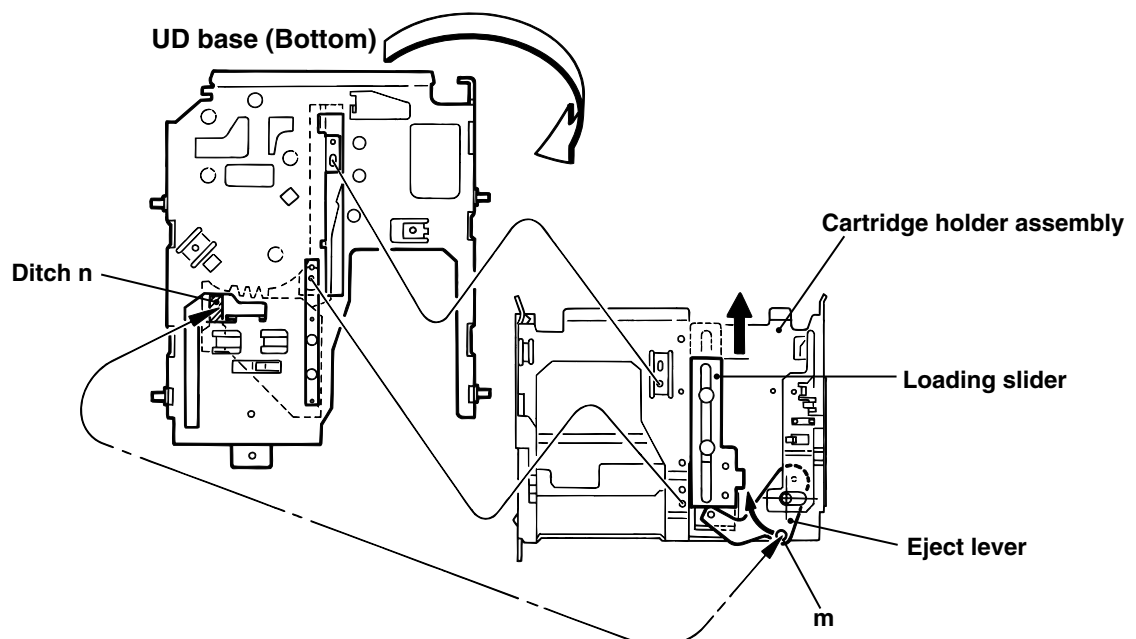
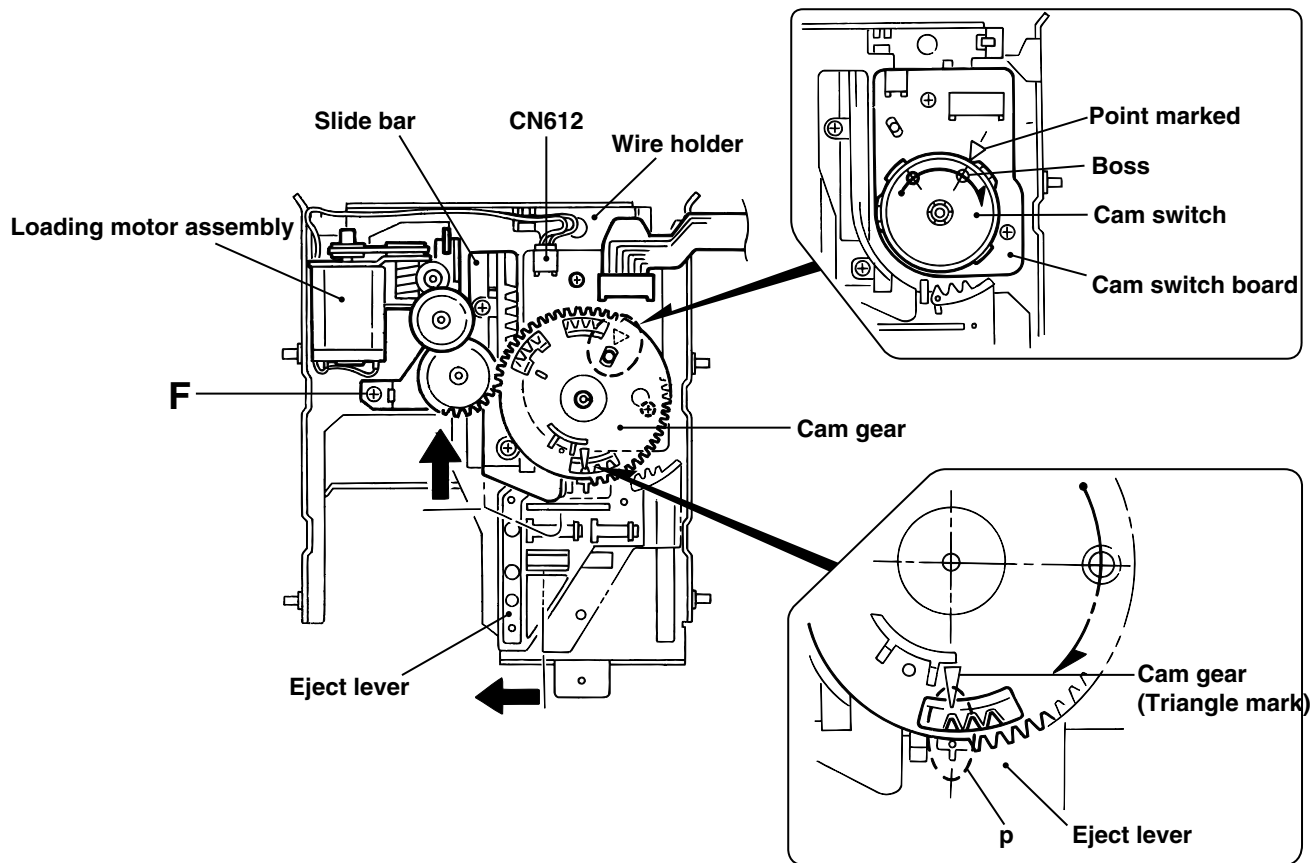

Fig.22

4. Reattach the wire holder to the UD base while engaging the UD base hook marked **r** to the wire holder slot marked **q** (At the same time, the boss on the reverse side of the wire holder is fitted to the UD base round hole).
5. Reattach the cam switch board using the two screws **H**. (**Fig.23**)
6. Turn the cam switch to bring the boss to the point marked  $\Delta$  on the cam switch board. Reattach the cam gear using a slit washer while fitting the cam gear slot to the cam switch boss. (**Fig.23**)

**ATTENTION:** When reattaching the cam gear, the cam switch boss should be fitted to the cam gear slot, and the triangle mark of the cam gear should be aligned to the hole(part **p**) of the eject lever as shown in **Fig.23**.

7. Reattach the loading motor assembly, using the screw **F**. Connect the harness extending from the loading motor to connector CN612 on the switch board and fix it with the wire holder. (**Fig.23**)



**Fig.23**

8. Reattach the UD base while engaging the four pins on both sides of the UD base to the notches of the loading mechanism base and placing the edge (marked **e''**) of the cartridge holder assembly under the hook **e** of the loading mechanism base. (Fig.24)

9. Reattach the slide base (R) while fitting the two pins on another side of the UD base to the slots of the slide base (R). (Fig.25)

ATTENTION: Fit the part **s** of the slide base (R) to the part **t** on the inward side of the cam gear rib. (Fig.26)

10. Reattach the slide base (L) on the slide base (R) while fitting the two pins on another side of the UD base to the slots of the slide base (L) (Fig.26). Make sure the two slots of the slide base (L) are fitted to the two bosses marked **e'** and tighten the two screws **E**. (Fig.27)

Ref: To expedite the work, bring up the UD base slightly when fitting each pin to the appropriate notch.

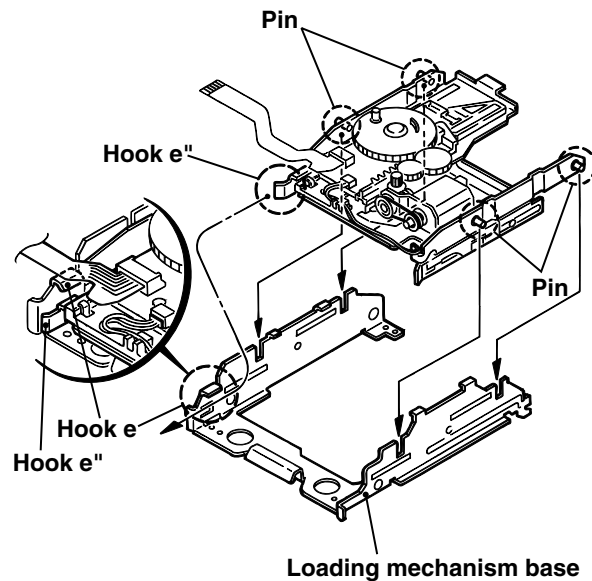

Loading mechanism base

Fig.24

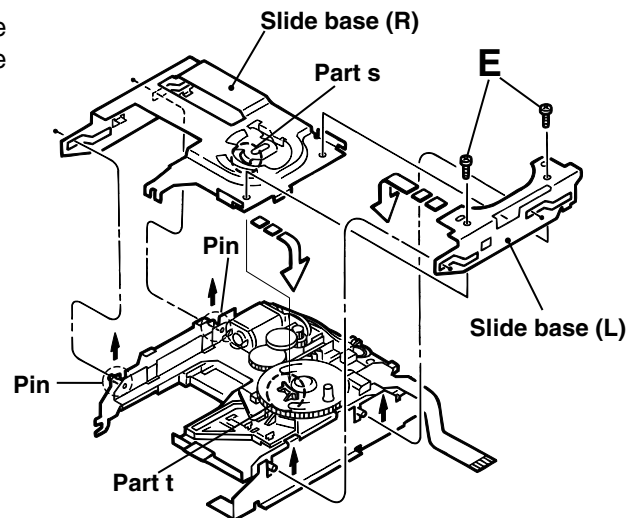

Fig.25

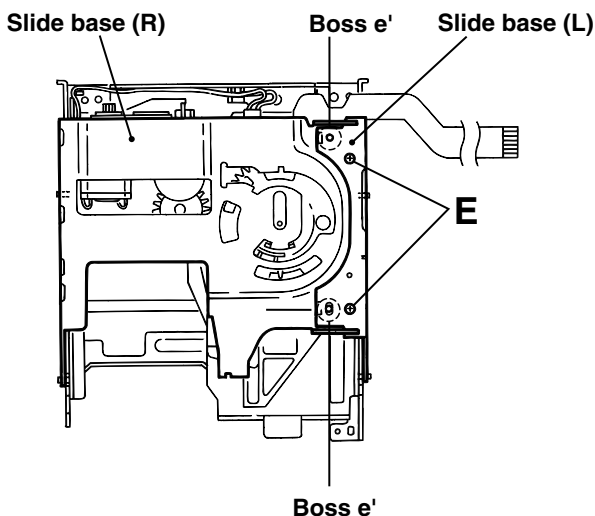

Fig.27

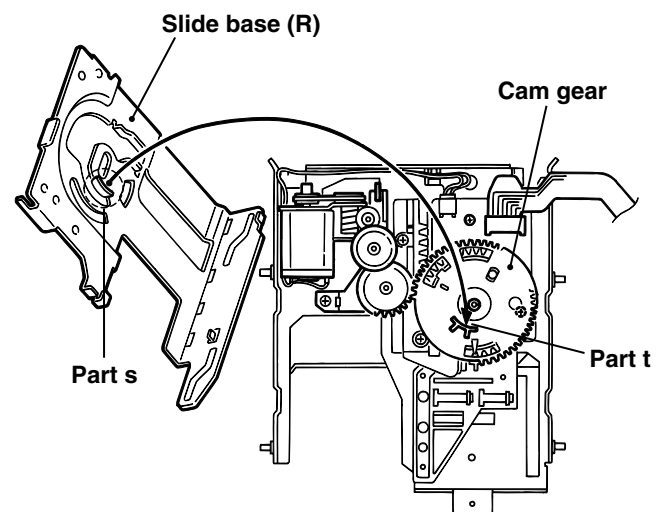

Fig.26

## Adjustment Method (CD/MD section)

### 1. Jigs and test instruments

- Laser power meter
- Laser power meter sensor (or disk sensor)
- Premastered disk (MRG-1018 or TGYS1)
- Recordable disk (MDW-74/AU1)

### 2. CD check method

1. Remove the four screws retaining the top cover from the rear panel and the two screws retaining it from the left and right side panels.
2. Remove the two screws retaining the front cover from the rear side and the two screws retaining it from the bottom panel.
3. Remove the eight screws retaining the rear cover.
4. Remove the four screws retaining the sub chassis from the left and right sides.

**(Caution)** For details of the removal, see the previous section "Disassembly method".

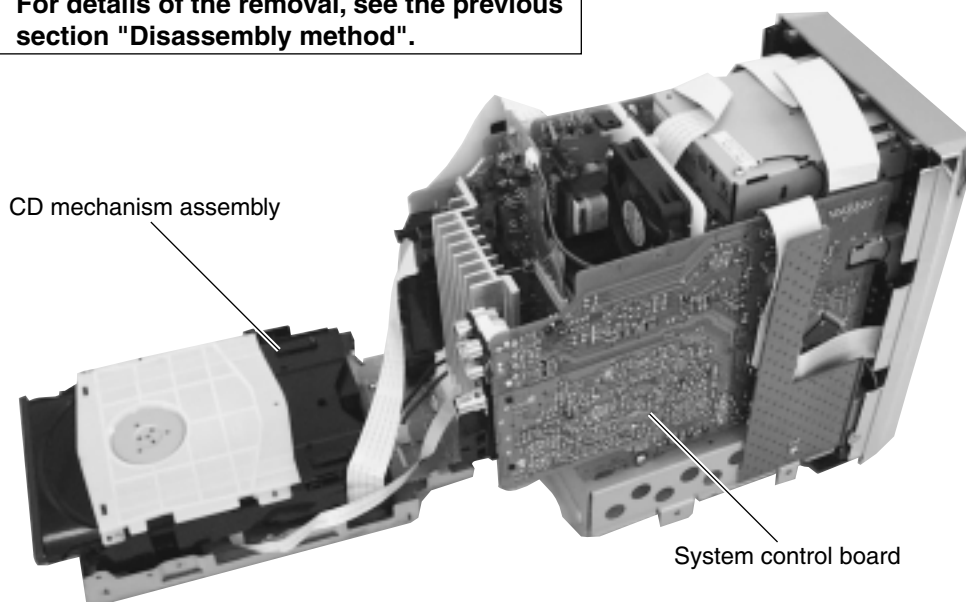

### 3. USB input check method

Connect the PC to the USB port and ensure that audio is output from the speakers.  
(Compatible with Windows 98, Windows 2000 and Windows Me)

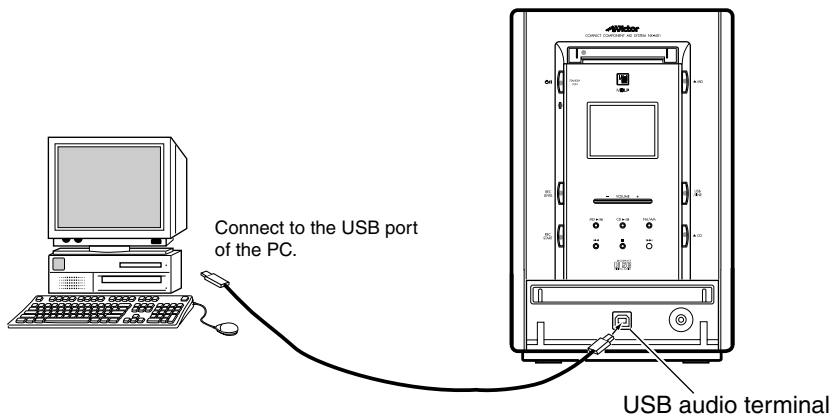



## 4. Adjustment and check items

### 1) CD section

- (1) Indication of the C1 error
- (2) Cancel of the C1 error indication

### 2) MD section

- (1) Setup of the TEST MODE 1
- (2) Initialization of the EEPROM
- (3) Adjustment of the laser power
- (4) Adjustment of the disk
- (5) Setup of the TEST MODE 2
- (6) Indication of variation in the pickup adjustment value
- (7) Indication of the C1 error
- (8) Cancel of the TEST MODE

## 5. Adjustment and check method

### 1) CD section

- (1) Indication of the C1 error

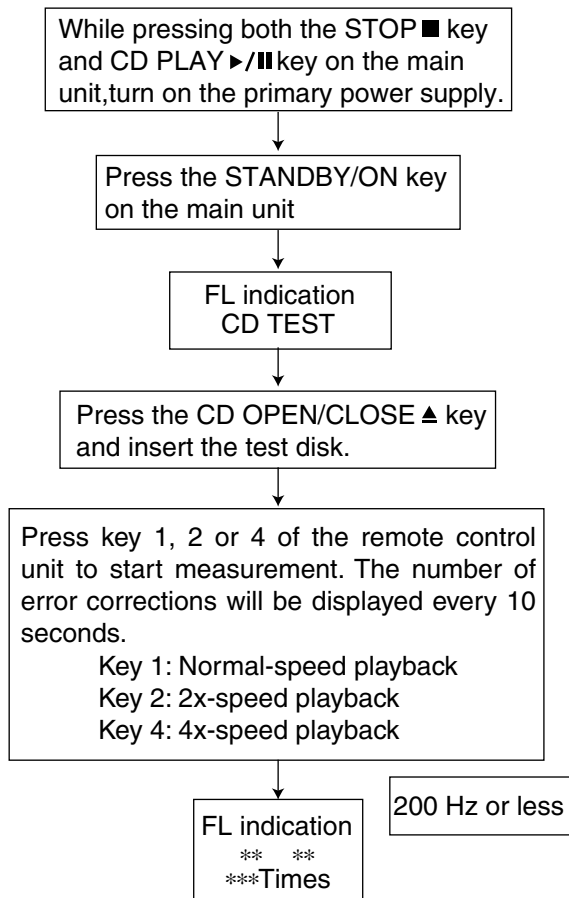

- (2) Cancel of the C1 error indication  
To cancel the C1 error indication, cut off the power supply.

2) MD section

(1) Setup of the TEST MODE 1

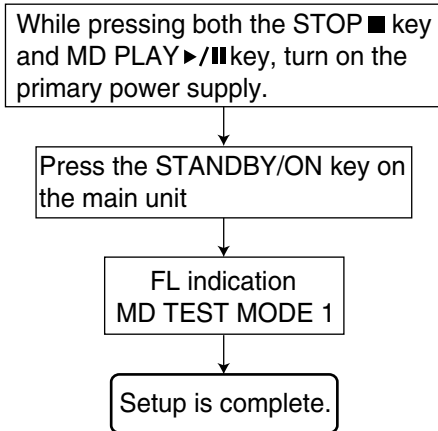

(2) Initialization of the EEPROM

(The EEPROM can be initialized on the precondition that the setup of the TEST MODE 1 is complete. After setup of the TEST MODE 1, proceed to the following operations with the remote controller\*.)

\* For EJECT operation, use the EJECT key on the main unit.

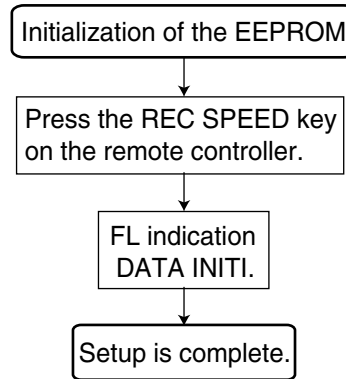

(3) Adjustment of the playback laser power

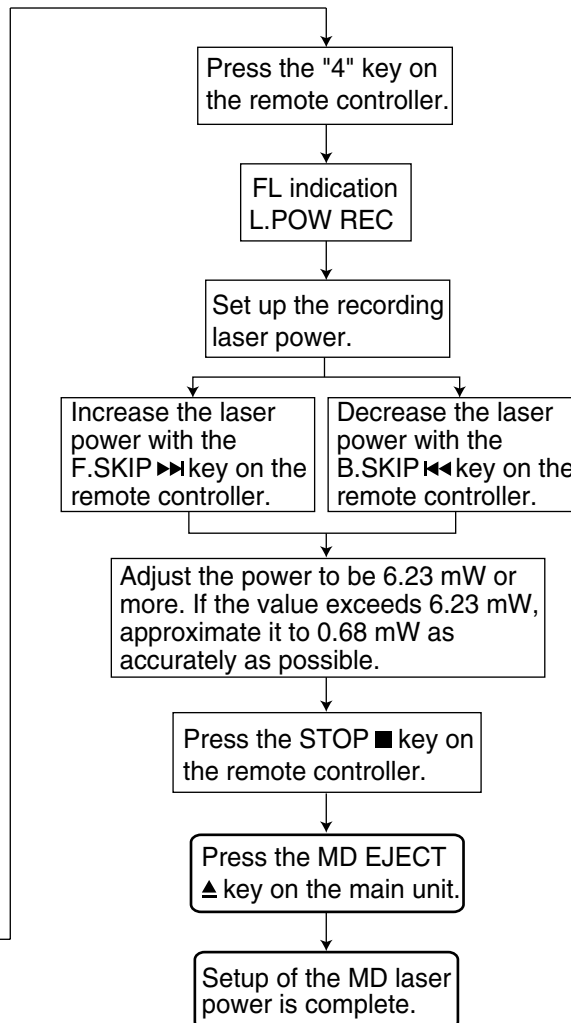
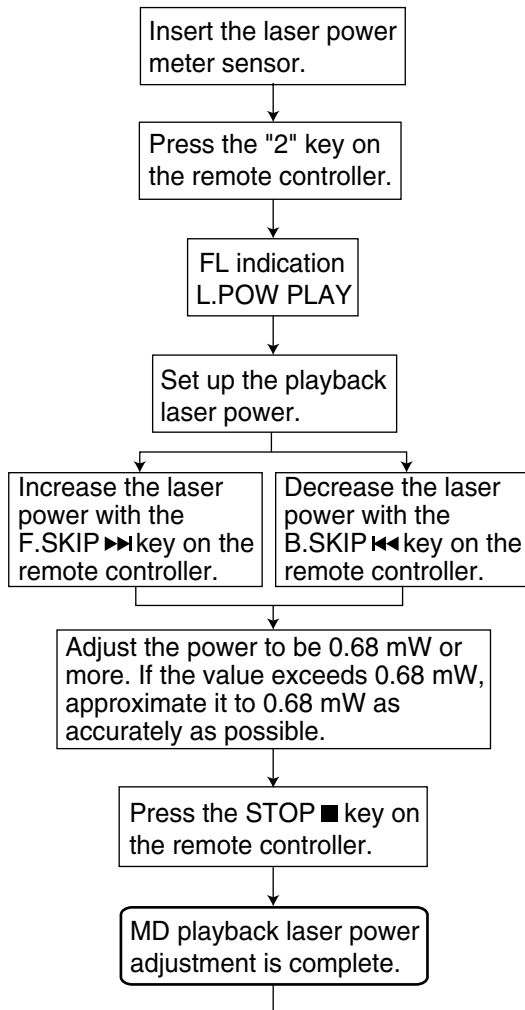

(4) Adjustment of the disk

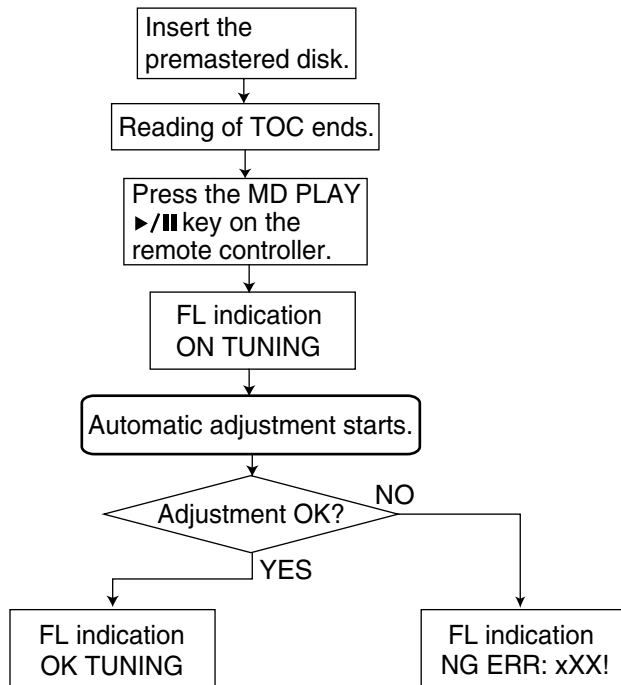

XX: Refer to the NG judgment code table.

NG Judgment Code Table

Code	NG item in adjustment
00	Automatic adjustment is incomplete.
01	Rest switch detection
02	Focus-on
03	EF balance, tracking offset adjustment (Pit area)
04	ABCD level (I-V resistance) adjustment (Pit area)
05	Focus servo AGC (Pit area)
06	Tracking servo AGC (Pit area)
07	Focus bias adjustment (Pit area)
08	EF balance, tracking offset adjustment (GRV area)
09	ABCD level (I-V resistance) adjustment (GRV area)
0A	Focus servo AGC (GRV area)
0B	Tracking servo AGC (GRV area)
0C	Focus bias adjustment (GRV area)
0D	Room temperature measurement
0E	Write in EEPROM
FF	Automatic adjustment is complete.

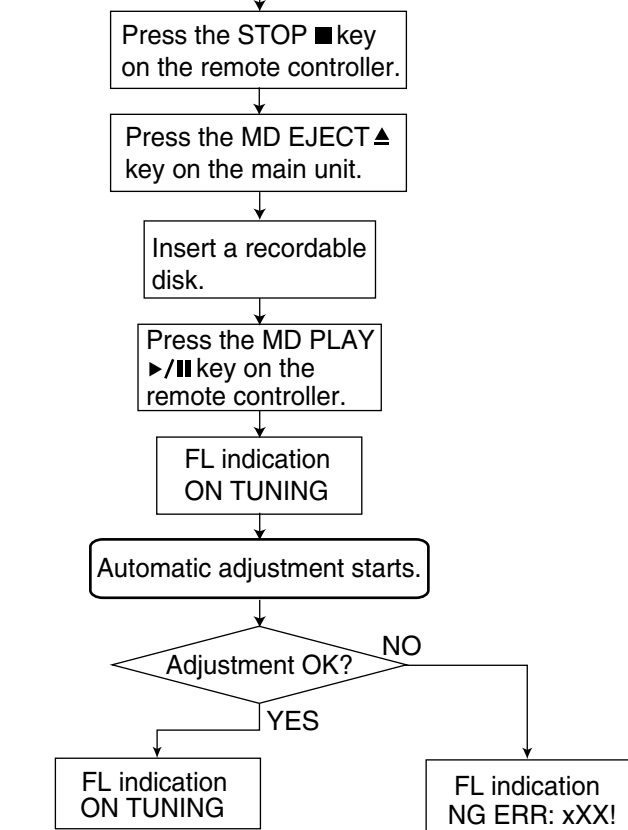

Refer to the NG judgment code table.

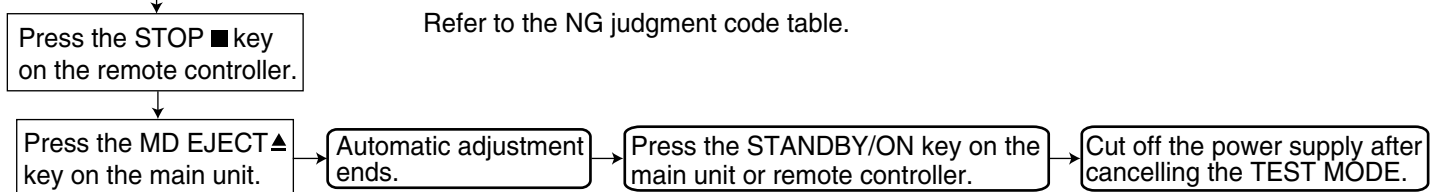

For investigating the mode in which an error occurred during the disk adjustment, freeze the set in the mode by pressing the proper key (refer to the table on the right) on the remote controller before cancelling the TEST MODE 1.

Key to press	Mode
SLEEP key (Remote controller)	FOCUS SEARCH
"6" key (Remote controller)	PIT ROUGH SERVO
"7" key (Remote controller)	GROOVE ROUGH SERVO
"8" key (Remote controller)	TRACKING ON
"9" key (Remote controller)	TRACKING OFF
STOP key (Remote controller)	STOP
EJECT key (Main unit)	EJECT

(5) Setup of the TEST MODE 2

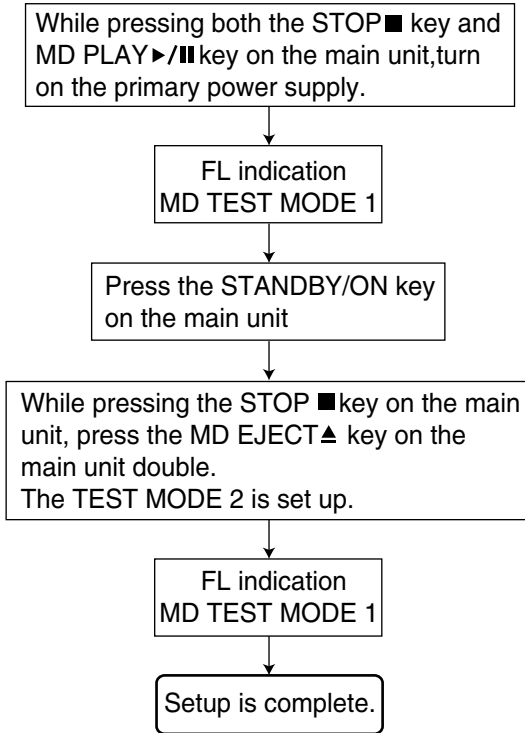

(6) Indication of variation in the pickup adjustment value

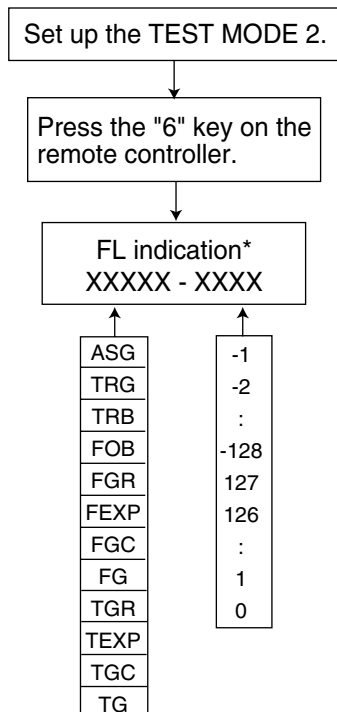

\*Each time the "6" key on the remote controller is pressed, the indication changes from ASG to TRG, from TRG to TRB, and so on as shown in the figure.

(7) Indication of the C1 error

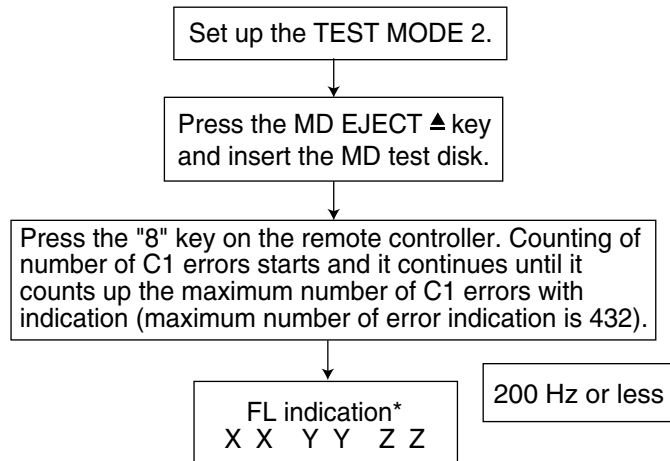

(8) Cancel of the TEST MODE

(The cancel operation is common to the TEST MODE 1 and 2.)

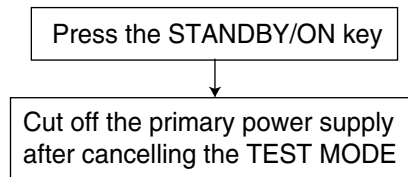

# Flow of functional operation until TOC read (CD)

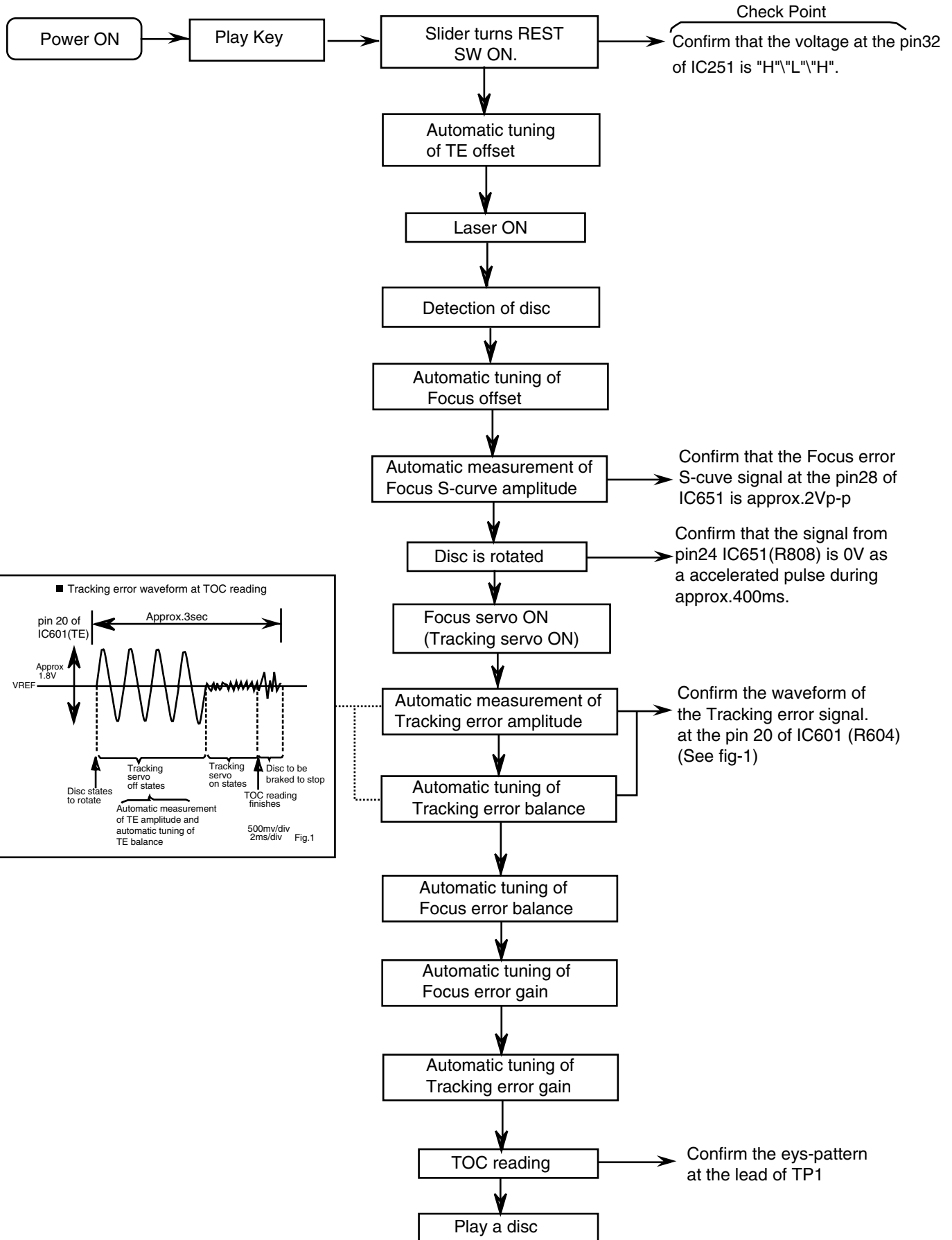

## Flow of functional operation until TOC read (MD)

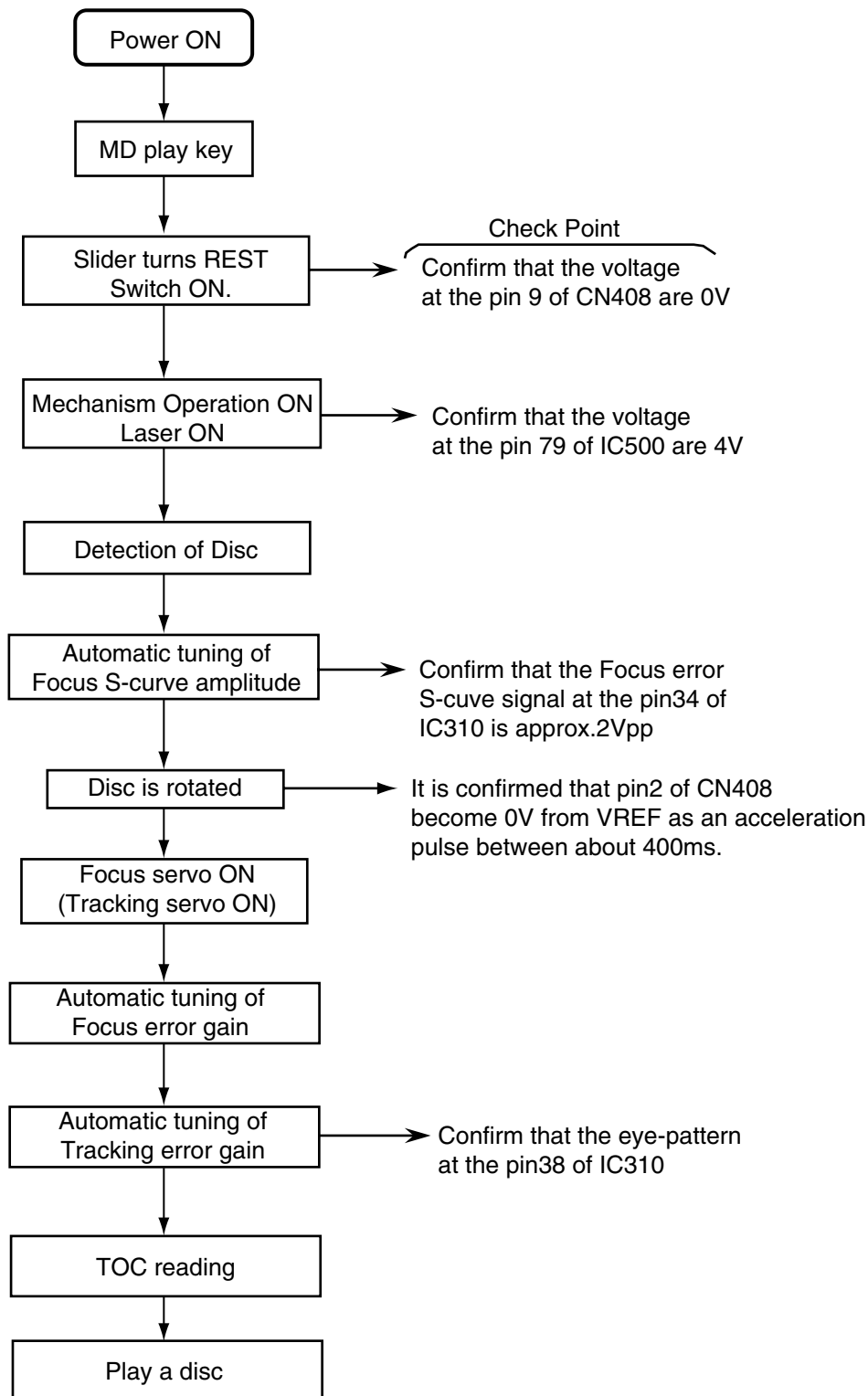

## Maintenance of laser pickup (CD) Replacement of laser pickup (CD)

- (1) Cleaning the pick up lens  
Before you replace the pick up, please try to clean the lens with a alcohol soaked cotton swab.
- (2) Life of the laser diode  
When the life of the laser diode has expired, the following symptoms will appear.
1. The level of RF output (EFM output: amplitude of eye pattern) will below.

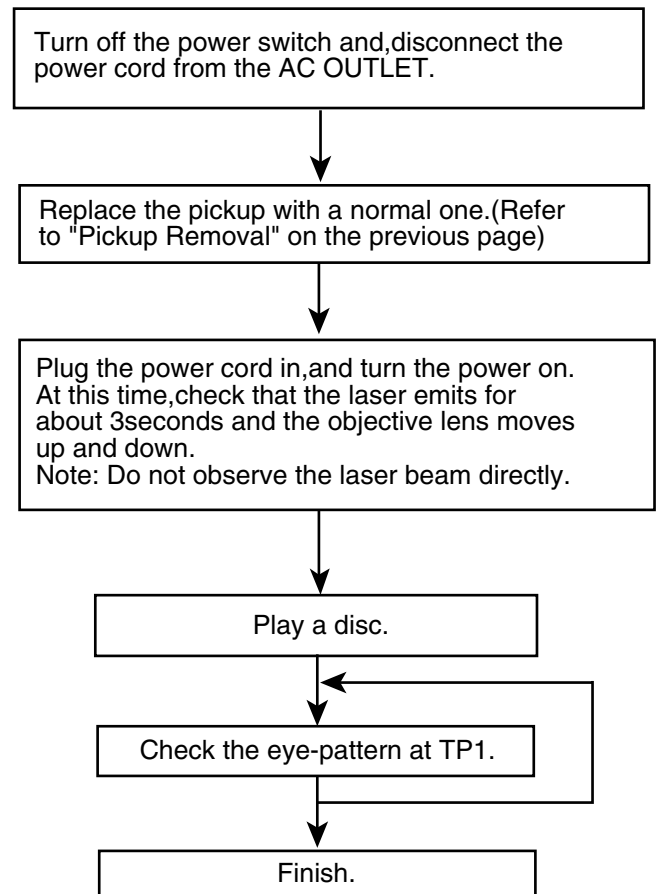
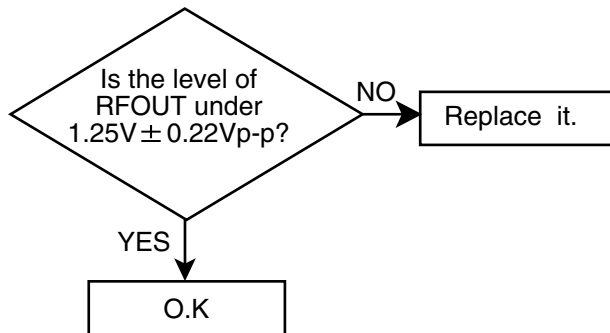

- (3) Semi-fixed resistor on the APC board  
The semi-fixed resistor on the APC board which is attached to the pickup is used to adjust the laser power. Since this adjustment should be performed to match the characteristics of the whole optical block, do not touch the semi-fixed resistor.  
If the laser power is lower than the specified value,the laser diode is almost worn out, and the laser pickup should be replaced.  
If the semi-fixed resistor would be adjusted when the pickup operates normally,the laser pickup may be damaged due to excessive current.

# Maintenance of laser pickup (MD) Replacement of laser pickup (MD)

## 1. Cleaning of pickup lens

Prior to changing the pickup, clean the pickup lens.

## 2. Confirmation of the service life of laser diode when the service life of the laser diode has been exhausted, the following symptoms will appear.

- (1) Recording will become impossible.
- (2) The RF output (EFM output and eye pattern amplitude) will become lower.
- (3) The drive current required for light emitting of laser diode will be increased.

Confirm the service life according to the following flow chart:

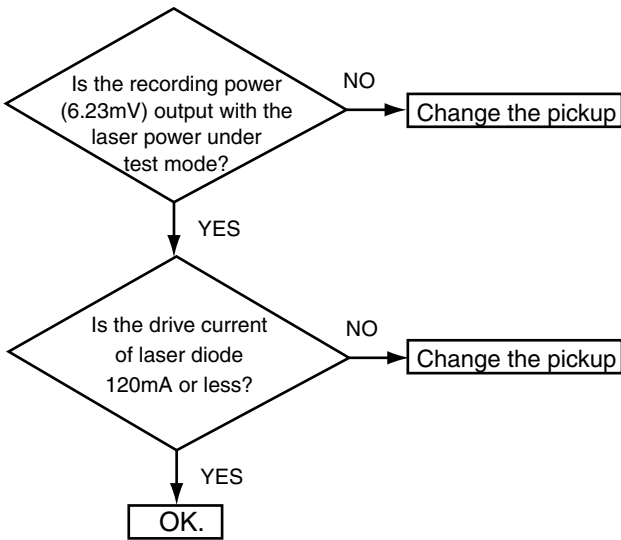

## 3. Method of measuring the drive current of laser diode

When the voltage measured at R337(both end) of the MD servo board (ENX-0223) have become 120mV or over, the service life of the laser diode is judged to have been exhausted.

[Caution] When both R337 have been shorted on such an occasion, then the laser diode will be broken. Therefore, take utmost care in handling the MD pickup.

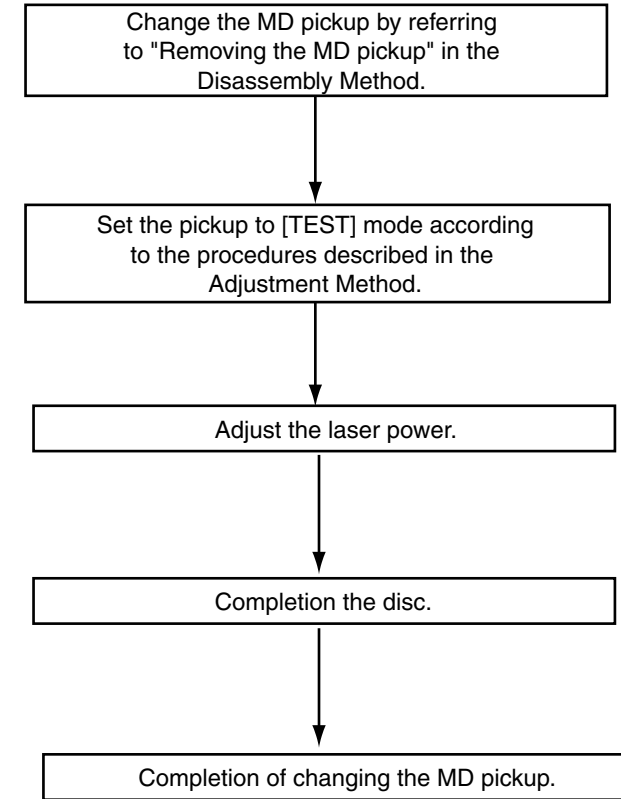

Since this system is designed to perform magnetic recording, the laser power ten times or over of the conventional MD player will be output. Therefore, be sure to perform not only adjustment and operation of this system so carefully as not to directly look at the laser beam or touch on the body.

## 4. Semi-solid state resistors on the APC board

The semi-solid state resistor on the APC board attached to the pickup is used for adjusting the laser power. Since these resistor should be adjusted in pair according to the characteristics of the optical block, be sure not to touch on the resistors.

Since the service life of the laser diode will be exhausted when the laser power is low, it is necessary to change the pickup. Meanwhile, do not pickup. Otherwise, the pickup will be damaged due to over current.



# Description of major ICs

## ■ AK4519VF (IC480) : A/D, D/A converter

### 1. Terminal layout

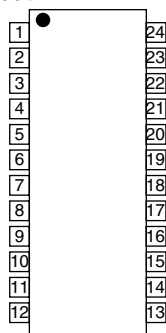

### 2. Block diagram

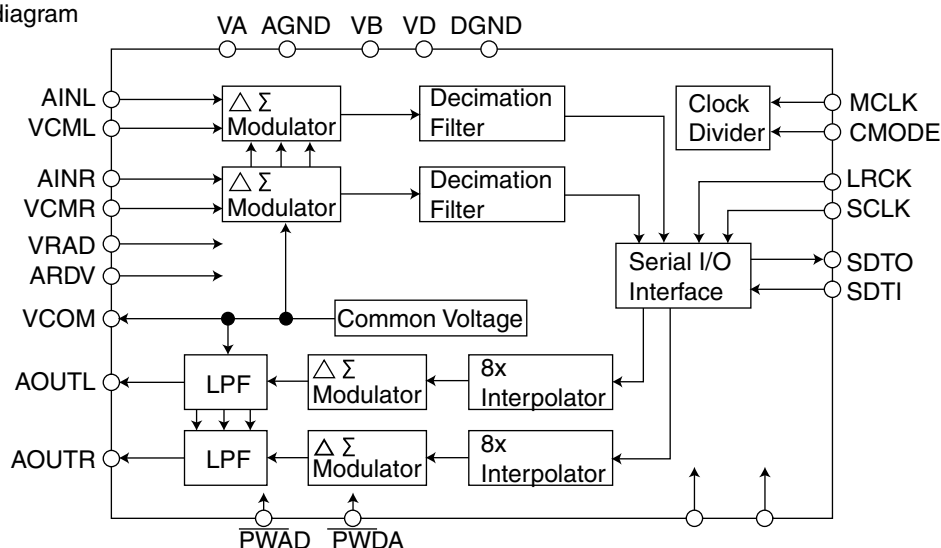

### 3. Pin Function

Pin NO.	Symbol	I/O	Function
1	VRDA	I	Voltage Reference Input Pin for DAC, VA
2	VRAD	I	Voltage Reference Input Pin for ADC, VA
3	AINR	I	RCh Analog Input Pin
4	VCMR	O	Rch Common Voltage Output Pin, 0.45xVA
5	VCML	O	Lch Common Voltage Output Pin, 0.45xVA
6	AINL	I	Lch Analog Input Pin
7	PWAD	I	ADC Power-Down Mode Pin "L":Power Down
8	PWDA	I	DAC Power-Down Mode Pin "L":Power Down
9	MCLK	I	Master Clock Input Pin
10	LRCK	I	Input/Output Channel Clock Pin
11	SCLK	I	Audio Serial Data Clock Pin
12	SDTO	O	Audio Serial Data Output Pin
13	DGND	-	Digital Ground Pin
14	VD	-	Digital Power Supply Pin
15	SDTI	I	Audio Serial Data Input Pin
16	CMODE	I	Master Clock Select Pin
17	DEM1	I	De-emphasis Frequency Select Pin
18	DEM0	I	De-emphasis Frequency Select Pin
19	AOUTL	O	Lch Analog Output Pin
20	AOUTR	O	Rch Analog Output Pin
21	VCOM	O	Common Voltage Output Pin, 0.45xVA
22	AGND	-	Analog Ground Pin
23	VB	-	Substrate Pin
24	VA	-	Analog Power Supply Pin

**AN22000A(IC601):RF & SERVO AMP**

1. Terminal layout

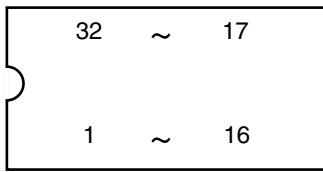

2. Block diagram

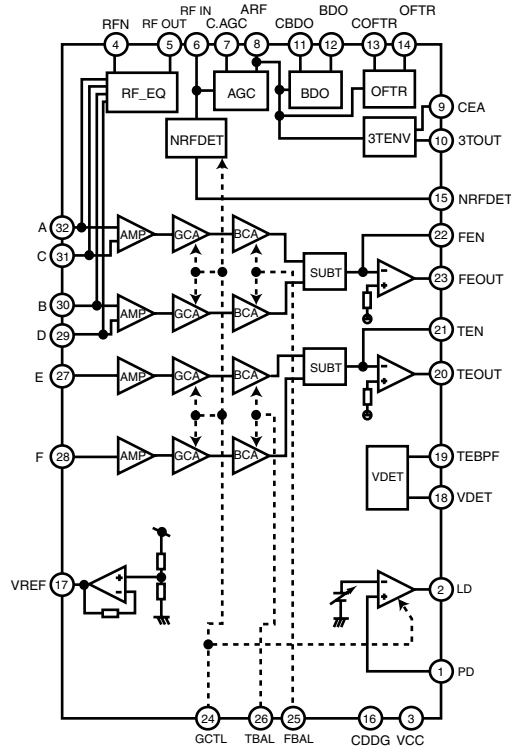

3. Pin function

Pin No.	Symbol	Function	Pin No.	Symbol	Function
1	PD	APC Amp. Input terminal	16	CDDG	Earth terminal
2	LD	APC Amp. Output terminal	17	VREF	VREF output terminal
3	VCC	Power supply terminal	18	VDET	VDET output terminal
4	RFN	RF addition Amp. Reversing input terminal	19	TEBPF	VDET input terminal
5	RF OUT	RF addition Amp. Output terminal	20	TEOUT	TE Amp. output terminal
6	RF IN	AGC input terminal	21	TEN	TE Amp. reversing input terminal
7	C.AGC	Terminal of connection of capacity of AGC loop filter.	22	FEN	FE Amp. reversing input terminal
8	ARF	AGC output terminal	23	FEOOUT	FE Amp. output terminal
9	CEA	Capacity connection terminal for HPF-Amp.	24	GCTL	Terminal GCTL & APC
10	3TOUT	3TENV output terminal	25	FBAL	FBAL control terminal
11	CBDO	Capacity connection terminal for RF shade side envelope detection	26	TBAL	TBAL control terminal
12	BDO	BDO output terminal	27	E	Tracking signal input terminal 1
13	COFTR	Capacity connection terminal for RF discernment side envelope detection	28	F	Tracking signal input terminal 2
14	OFTR	OFTR output terminal	29	D	Focus signal input terminal 4
15	NRFDET	NRFDET output terminal	30	B	Focus signal input terminal 2
			31	C	Focus signal input terminal 3
			32	A	Focus signal input terminal 1

## ■ BD7910FV (IC450) : Pre driver

### 1. Block diagram

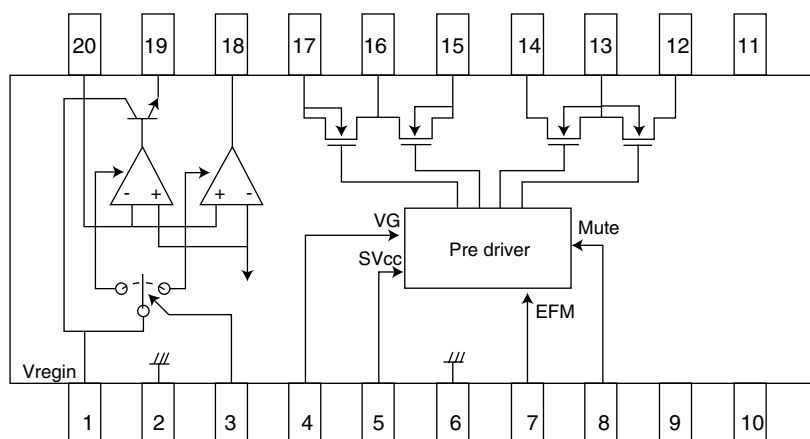

### 2. Pin function

Pin No.	Symbol	I/O	Function	Pin No.	Symbol	I/O	Function
1	Vreg IN	I	Regulator input and regulator power supply	11	NC	-	Non connect
2	Reg GN	-	Regulator GND	12	VOD2	O	Sync.output (Lower power MOS,drain)
3	NC	-	Non connect	13	VSS	-	"H"bridge GND (Lower power MOS,source)
4	VG	I	Voltage input for power MOS drive	14	VOD1	O	Sync.output (Lower power MOS,drain)
5	SVCC	O	EFM high level output voltage	15	VOS1	O	Source output (Upper power MOS,source)
6	PDGND	-	Pre-driver GND	16	VDD	-	"H" bridge power supply terminal (Upper power MOS,source)
7	EFM	I	EFM signal input	17	VOS2	O	Source output (Upper power MOS,source)
8	MUTE	I	Mute control (Low active)	18	Reg DRV	O	External PNP drive output for regulator
9	NC	O	Non connct	19	Reg OUT	O	Reglator output (Emitter follower output)
10	NC	O	Non connect	20	Reg NF	-	Regulator feedbaack terminal

■ BR93LC66F (IC590) : 256 x 16 bit serial EEPROM

1. Terminal layout

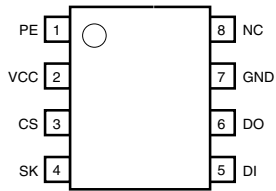

2. Block diagram

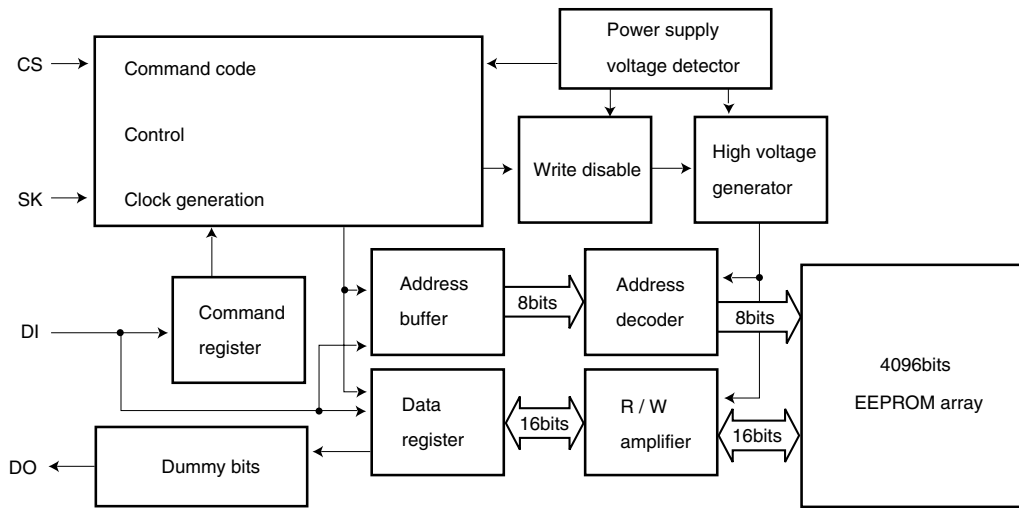

3. Pin function

Pin No.	Symbol	I/O	Function
1	PE	-	Not use
2	VCC	-	Power supply
3	CS	I	Chip select input
4	SK	I	Serial clock input
5	DI	I	Serial data input
6	DO	O	Serial data output
7	GND	-	Ground
8	NC	-	No connect

■ GP1U271X (IC721) : Receiver for remote

1. Block diagram

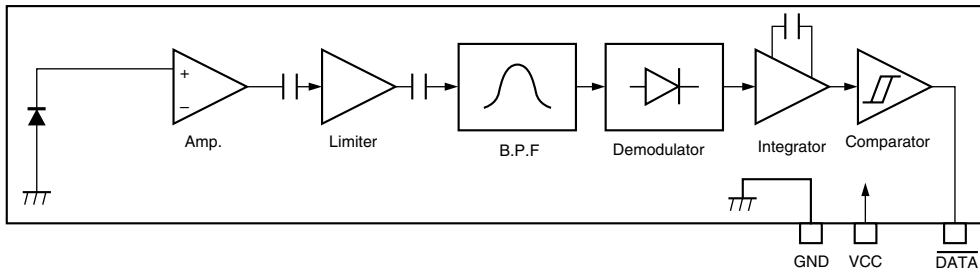

■ TC7S08F (IC340) : Buffer

1. Terminal layout

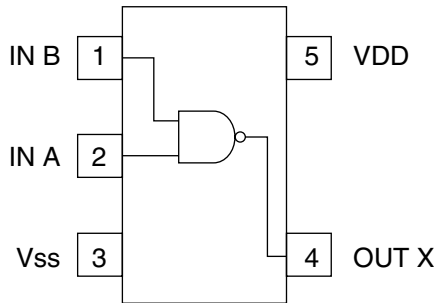

2. Block diagram

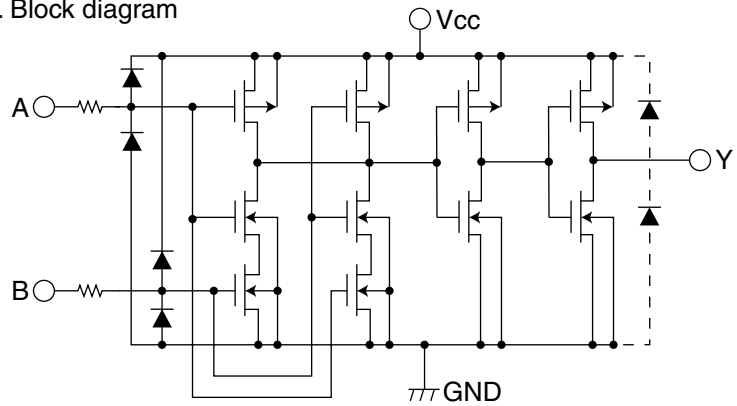

■ TK11140SC (IC485) : Regulator

1. Terminal layout

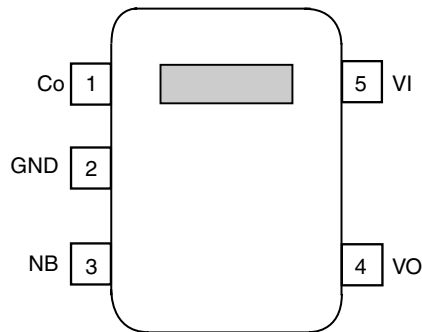

2. Block diagram

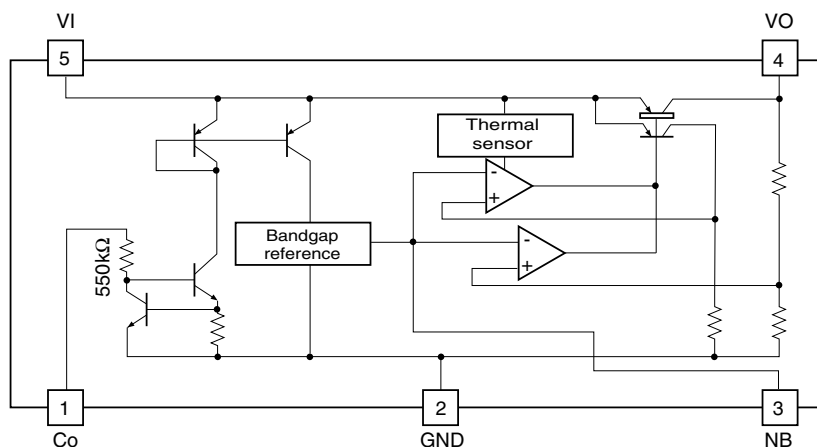

■ CXA2523AR (IC310) : MD servo

1. Block diagram

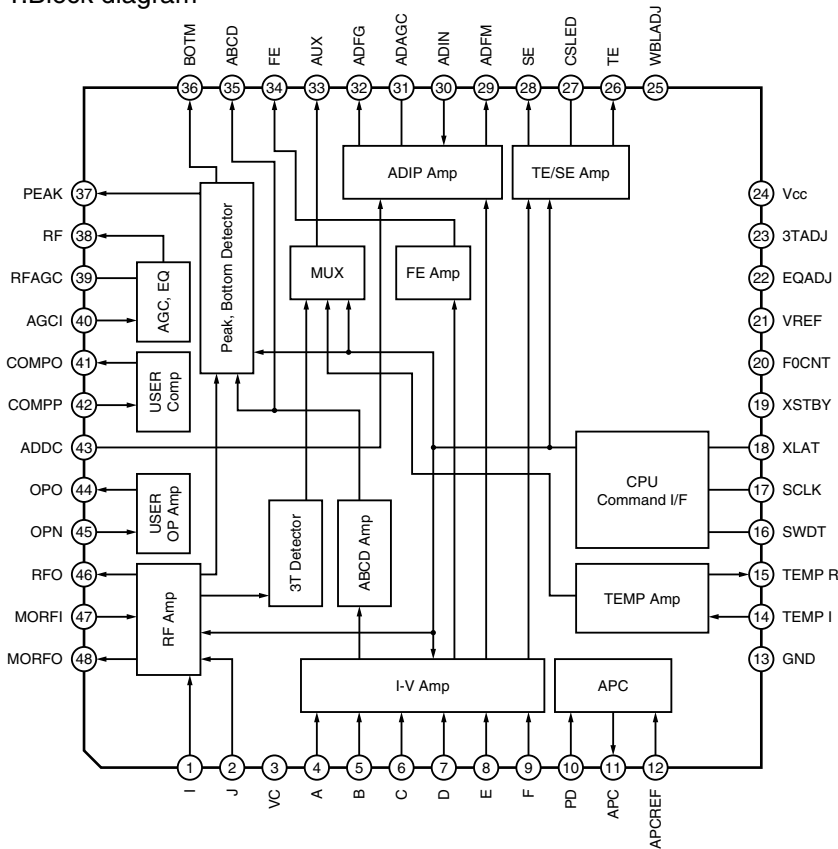

2. Pin function

Pin No.	Symbol	I/O	Function
1	I	I	I-V converted RF signal I input.
2	J	I	I-V converted RF signal J input.
3	VC	O	Vcc/2 voltage output.
4	A	I	A current input for main beam servo signal.
5	B	I	B current input for main beam servo signal.
6	C	I	C current input for main beam servo signal.
7	D	I	D current input for main beam servo signal.
8	E	I	E current input for side beam servo signal.
9	F	I	F current input for side beam servo signal.
10	PD	I	Reflection light quantity monitor signal input.
11	APC	O	Laser APC output.
12	APCREF	I	Reference voltage input for the laser power intensity setting.
13	GND	-	Connect to GND.
14	TEMPI	I	Connects the temperature sensor.
15	TEMP R	I	Connects the temperature sensor. outputs the reference voltage.
16	SWDT	I	Data input for microcomputer serial interface.
17	SCLK	I	Shift clock input for microcomputer serial interface.
18	XLAT	I	Latch signal input for microcomputer serial interface. Latched when low.
19	XSTBY	I	Standby setting pin. Normal operation when high Standby when low.
20	F0CNT	I	Internal current source setting pin.

Pin No.	Symbol	I/O	Function
21	VREF	O	Reference voltage output.
22	EQADJ	I/O	Equalizer center frequency setting pin.
23	3TADJ	I/O	BPF3T center frequency setting pin.
24	Vcc	-	Power supply.
25	WBLADJ	I/O	BPF22 center frequency setting pin.
26	TE	O	Tracking error signal output.
27	CSLED	-	Connects the sled error signal LPF capacitor.
28	SE	O	Sled error signal output.
29	ADFM	O	ADIP FM signal output.
30	ADIN	I	ADIP signal comparator input.
31	ADAGC	-	Connects the ADIPAGC capacitor.
32	ADFG	O	ADIP2 binary value signal output.
33	AUX	O	13 output / temperature signal output. Switched with serial commands.
34	FE	O	Focus error signal output.
35	ABCD	O	Reflection light quantity signal output for the main beam servo detector.
36	BOTM	O	RF/ABCD bottom hold signal output.
37	PEAK	O	Peak hold signal output for the RF/ABCD signals.
38	RF	O	RF equalizer output.
39	RFAGC	-	Connects the RFAGC capacitor.
40	AGCI	I	RFAGC input.
41	COMPO	O	User comparator output.
42	COMPP	I	User comparator non-inverted input.
43	ADDC	I/O	Connects the capacitor for ADIP amplifier feedback circuit.
44	OPO	O	User operational amplifier output.
45	OPN	I	User operational amplifier inverted input.
46	RFO	O	RF amplifier output. Eye pattern checkpoint.
47	MORFI	I	Input of the groove RF signal with AC coupling.
48	MORFO	O	Groove RF signal output.

■ CXD2662R (IC350) : DSP

1. Terminal layout

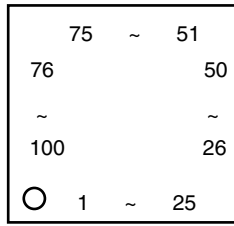

2. Block diagram

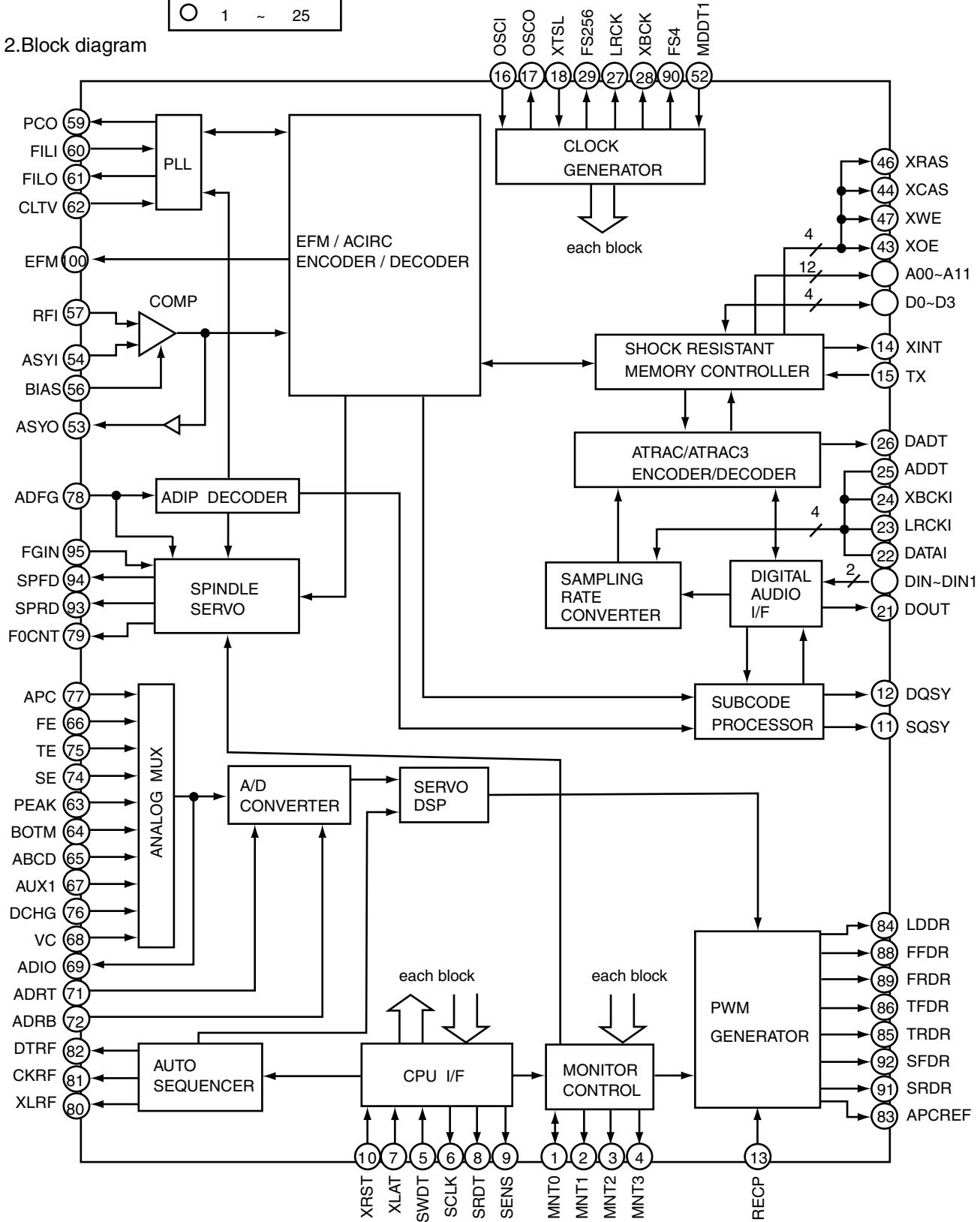



## 3.Pin function

Pin No.	Symbol	I/O	Function
1	MNT0	I/O	Monitor output.
2	MNT1	O	Monitor output.
3	MNT2	O	Monitor output.
4	MNT3	O	Monitor output.
5	SWDT	I	Data input for microcomputer serial interface.
6	SCLK	I	Shift clock input for microcomputer serial interface.
7	XLAT	I	Latch input for microcomputer serial interface.Latched at the falling edge.
8	SRDT	O	Data output for microcomputer serial interface.
9	SENS	O	Outputs the internal status corresponding to the microcomputer serial interface address.
10	XRST	I	Reset input. Low : reset
11	SQSY	O	Disc subcode Q sync / ADIP sync output.
12	DQSY	O	Subcode Q sync output in U-bit CD or MD format when the Digital In source is CD or MD.
13	RECP	I	Laser power switching input. High : recording power ; low ; playback power
14	XINT	O	Interruption request output. Low when the interruption status occurs.
15	TX	I	Enable signal input for recoding data output. High : enabled
16	OSCI	I	Crystal oscillation circuit input.
17	OSCO	O	Crystal oscillation circuit output. (inverted output of the OSCI pin)
18	XTSL	I	OSCI input frequency switching. XTSL1(command) = low and XTSL = high : 512Fs (22.5792MHz) XTSL1(command) = low and XTSL = low : 1024Fs (45.1584MHz) XTSL1(command) = high : 2048Fs (90.3168MHz)
19	DIN0	I	Digital audio interface signal input 1.
20	DIN1	I	Digital audio interface signal input 2.
21	DOUT	O	Digital audio interface signal output.
22	DATAI	I	Test pin. Connect to GND.
23	LRCKI	I	Test pin. Connect to GND.
24	XBCKI	I	Test pin. Connect to GND.
25	ADDT	I	Data input from A / D converter.
26	DADT	O	REC monitor output / decoded audio data output.
27	LRCK	O	LA clock (44.1kHz) output to the external audio block.
28	XBCK	O	Bit clock (2.8224kHz) output to the external audio block.
29	FS256	O	256Fs output.
30	DVDD	-	Digital power supply.
31	A03	O	External DRAM address output.
32	A02	O	External DRAM address output.
33	A01	O	External DRAM address output.
34	A00	O	External DRAM address output.
35	A10	O	External DRAM address output.
36	A04	O	External DRAM address output.
37	A05	O	External DRAM address output.
38	A06	O	External DRAM address output.
39	A07	O	External DRAM address output.
40	A08	O	External DRAM address output.
41	A11	O	External DRAM address output.
42	DVSS	-	Digital ground.
43	XOE	O	External DRAM output enable.

Pin No.	Symbol	I/O	Function
44	XCAS	O	External DRAM CAS output.
45	A09	O	External DRAM address output.
46	XRAS	O	External DRAM RAS output.
47	XWE	O	External DRAM write enable.
48	D1	I/O	External DRAM data bus.
49	D0	I/O	External DRAM data bus.
50	D2	I/O	External DRAM data bus.
51	D3	I/O	External DRAM data bus.
52	MDDTI	I	MD-DATA mode 1 switching input. (Low : normal mode ; high : MD-DATA mode 1)
53	ASYO	O	Playback EFM full-swing output. (Low : vss ; high : Vdd)
54	ASYI	I	Playback EFM comparator slice voltage input.
55	AVDD	-	Analog power supply.
56	BIAS	I	Playback EFM comparator bias current input.
57	RFI	I	Playback EFM RE signal input.
58	AVSS	-	Analog ground.
59	PCO	O	Phase comparison output for master PLL of playback digital PLL and recording EFM PLL.
60	FILI	I	Filter input for master PLL of playback digital PLL and recording EFM PLL.
61	FILO	O	Filter output for master PLL of playback digital PLL and recording EFM PLL.
62	CLTV	I	Internal VCO control voltage input for master PLL of playback digital EFM PLL and recording EFM PLL.
63	PEAK	I	Peak hold signal input for quantity of light.
64	BOTM	I	Bottom hold signal input for quantity of light.
65	ABCD	I	Signal input for quantity of light.
66	FE	I	Focus error signal input.
67	AUXI	I	Auxillary input 1.
68	VC	I	Center voltage input.
69	ADIO	I	Monitor output for A / D converter input signal.
70	AVDD	-	Analog power supply.
71	ADRT	I	Voltage input for the upper limit of the A / D converter operating range.
72	ADRB	I	Voltage input for the lower limit of the A / D converter operating range.
73	AVSS	-	Analog ground.
74	SE	I	Sled error signal input.
75	TE	I	Tracking error signal input.
76	DCHG	I	Connect to the low-impedance power supply.
77	APC	I	Error signal input for laser digital APC.
78	ADFG	I	ADIP binary FM signal (22.05 ± 1kHz) input.
79	F0CNT	O	CXA2523 current source setting output.
80	XLRF	O	CXA2523 control latch output. Latched at the falling edge.
81	CKRF	O	CXA2523 control shift clock output.
82	DTRF	O	CXA2523 control data output.
83	APCREF	O	Reference PWM output for laser APC.
84	LDDR	O	PWM output for laser digital APC.
85	TRDR	O	Tracking servo drive PWM output. (-)
86	TFDR	O	Tracking servo drive PWM output. (+)
87	DVDD	-	Digital power supply.
88	FFDR	O	Focus servo drive PWM output. (+)
89	FRDR	O	Focus servo drive PWM output. (-)
90	FS4	O	4Fs output. (176.4kHz)

Pin No.	Symbol	I/O	Function
91	SRDR	O	Sled servo drive PWM output. (-)
92	SFDR	O	Sled servo drive PWM output. (+)
93	SPRD	O	Spindle servo drive output. (PWM (-) or polarity)
94	SPFD	O	Spindle servo drive output. (PWM (+) or PWM absolute value)
95	FGIN	I	Spindle CAV servo FG input.
96	TEST1	I	Test pin. Connect to GND.
97	TEST2	I	Test pin. Connect to GND.
98	TEST3	I	Test pin. Connect to GND.
99	DVSS	-	Digital ground.
100	EFMO	O	Low when playback ; EFM (encoded data) output when recording.

■ LA1838 (IC1): FM AM IF AMP&detector, FM MPX decoder

1. Block Diagram

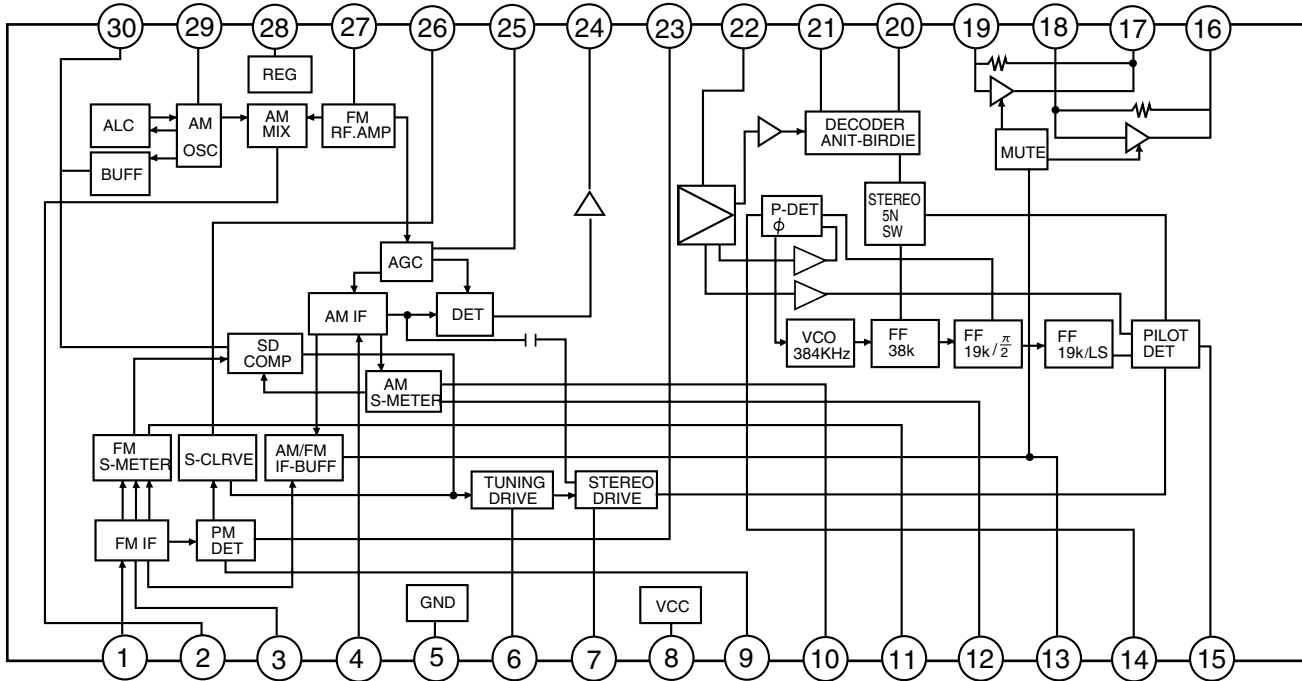

2. Pin Function

Pin No.	Symbol	I/O	Function	Pin No.	Symbol	I/O	Function
1	FM IN	I	This is an input terminal of FM IF signal.	16	L OUT	O	Left channel signal output.
2	AM MIX	O	This is an out put terminal for AM mixer.	17	R OUT	O	Right channel signal output.
3	FM IF	I	Bypass of FM IF	18	L IN	I	Input terminal of the left channel post AMP.
4	AM IF	I	Input of AM IF Signal.	19	R IN	I	Input terminal of the right channel post AMP.
5	GND	—	This is the device ground terminal.	20	RO	O	Mpx Right channel signal output.
6	TUNED	O	When the set is tuning, this terminal becomes "L".	21	LO	O	Mpx Left channel signal output.
7	STEREO	O	Stereo indicator output. Stereo "L", Mono: "H"	22	IF IN	I	Mpx input terminal
8	VCC	—	This is the power supply terminal.	23	FM OUT	O	FM detection output.
9	FM DET	—	FM detect transformer.	24	AM DET	O	AM detection output.
10	AM SD	—	This is a terminal of AM ceramic filter.	25	AM AGC	I	This is an AGC voltage input terminal for AM
11	FM VSM	O	Adjust FM SD sensitivity.	26	AFC	—	This is an output terminal of voltage for FM-AFC.
12	AM VSM	O	Adjust AM SD sensitivity.	27	AM RF	I	AM RF signal input.
13	MUTE	I/O	When the signal of IF REQ of IC121( LC72131) appear, the signal of FM/AM IF output. //Muting control input.	28	REG	O	Register value between pin 26 and pin28 desides the frequency width of the input signal.
14	FM/AM	I	Change over the FM/AM input. "H" :FM, "L" : AM	29	AM OSC	—	This is a terminal of AM Local oscillation circuit.
15	MONO/ST	O	Stereo : "H", Mono: "L"	30	OSC BUFFER	O	AM Local oscillation Signal output.

## ■ LA4628 (IC301) : 2ch BTL AF power amplifier

### 1. Terminal layout

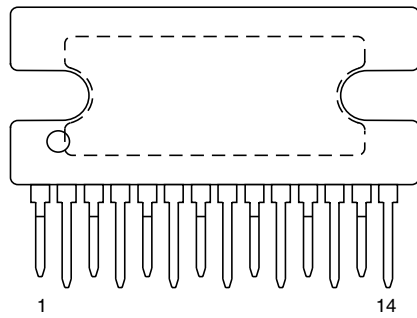

### 2. Block diagram

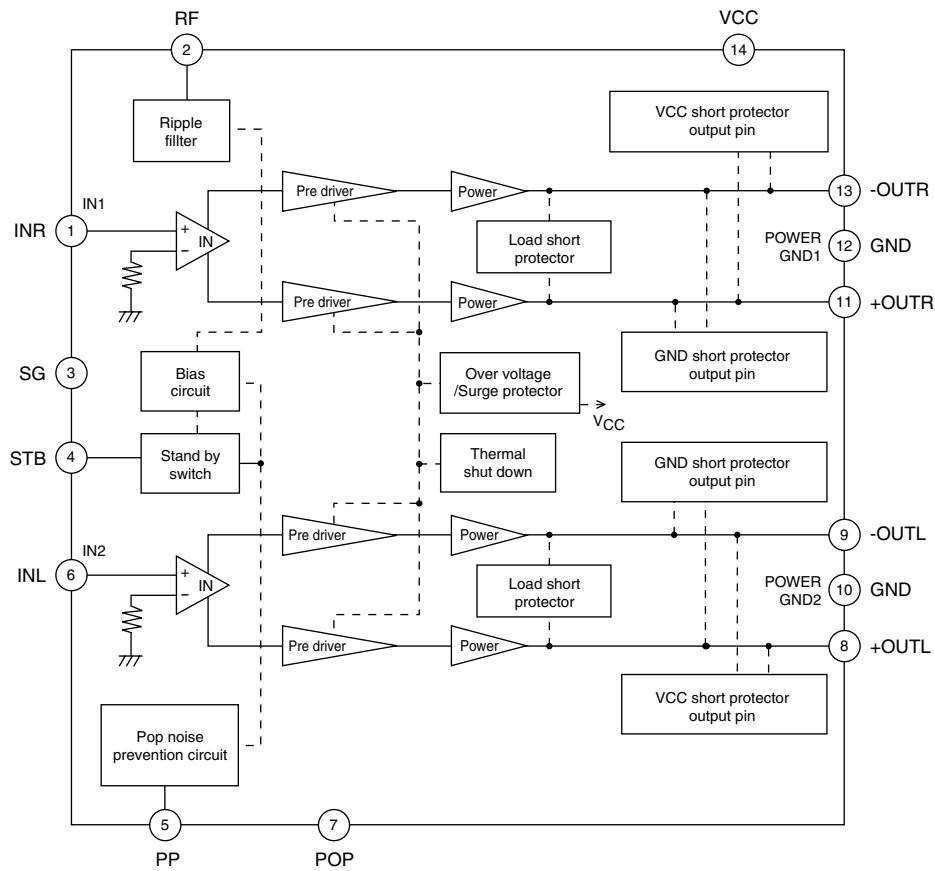

■ LA6541 (IC801) : Servo driver

1. Terminal Layout & block diagram

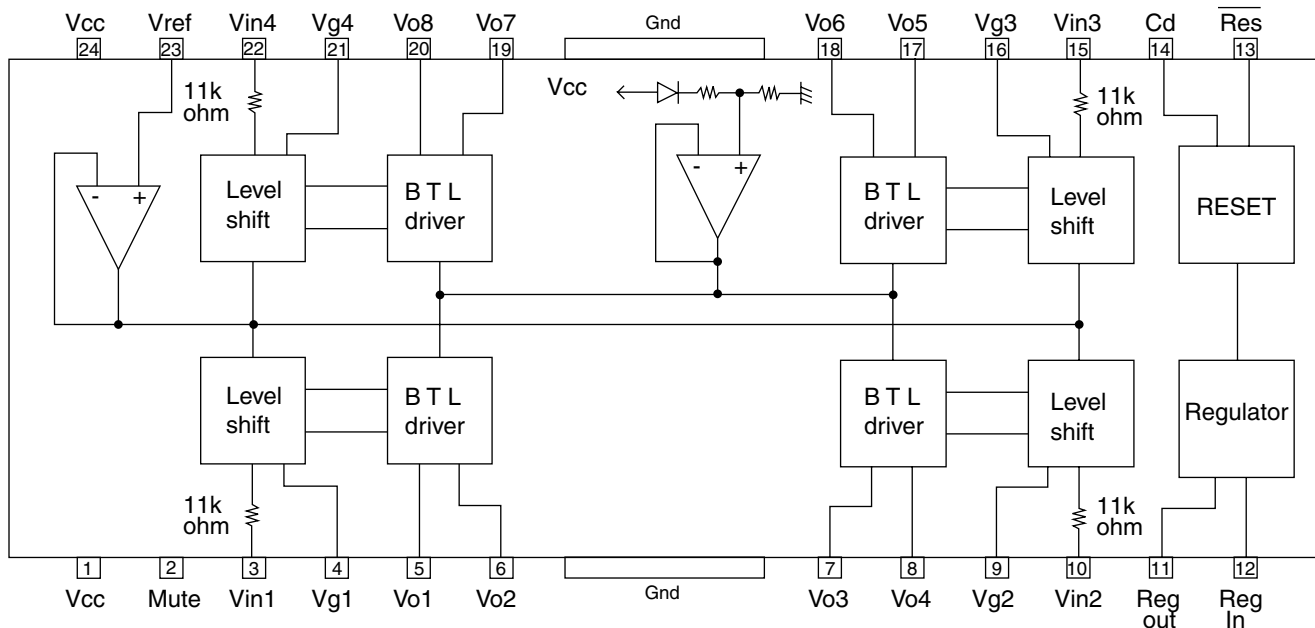

2. Pin function

Pin No.	Symbol	Function
1	Vcc	Power supply (Shorted to pin 24)
2	Mute	All BTL amplifier outputs ON/OFF
3	Vin1	BTL AMP 1 input pin
4	Vg1	BTL AMP 1 input pin (For gain adjustment)
5	Vo1	BTL AMP 1 input pin (Non inverting side)
6	Vo2	BTL AMP 1 input pin (Inverting side)
7	Vo3	BTL AMP 2 input pin (Inverting side)
8	Vo4	BTL AMP 2 input pin (Non inverting side)
9	Vg2	BTL AMP 2 input pin (For gain adjustment)
10	Vin2	BTL AMP 2 input pin
11	Reg Out	External transistor collector (PNP) connection. 5V power supply output
12	Reg In	External transistor (PNP) base connection
13	Res	Reset output
14	Cd	Reset output delay time setting (Capacitor connected externally)
15	Vin3	BTL AMP 3 input pin
16	Vg3	BTL AMP 3 input pin (For gain adjustment)
17	Vo5	BTL AMP 3 output pin (Non inverting side)
18	Vo6	BTL AMP 3 output pin (Inverting side)
19	Vo7	BTL AMP 4 output pin (Inverting side)
20	Vo8	BTL AMP 4 output pin (Non inverting side)
21	Vg4	BTL AMP 4 output pin (For gain adjustment)
22	Vin4	BTL AMP 4 output pin
23	Vref	Level shift circuit's reference voltage application
24	Vcc	Power supply (Shorted to pin 1)

## ■ LC72136N (IC2) : PLL frequency synthesizer

### 1. Terminal layout

XT	1	22	XT
FM/AM	2	21	GND
CE	3	20	LPFOUT
DI	4	19	LPFIN
CLOCK	5	18	PD
DO	6	17	VCC
FM/ST/VCO	7	16	FMIN
AM/FM	8	15	AMIN
	9	14	
	10	13	IFCONT
SDIN	11	12	IFIN

### 2. Block diagram

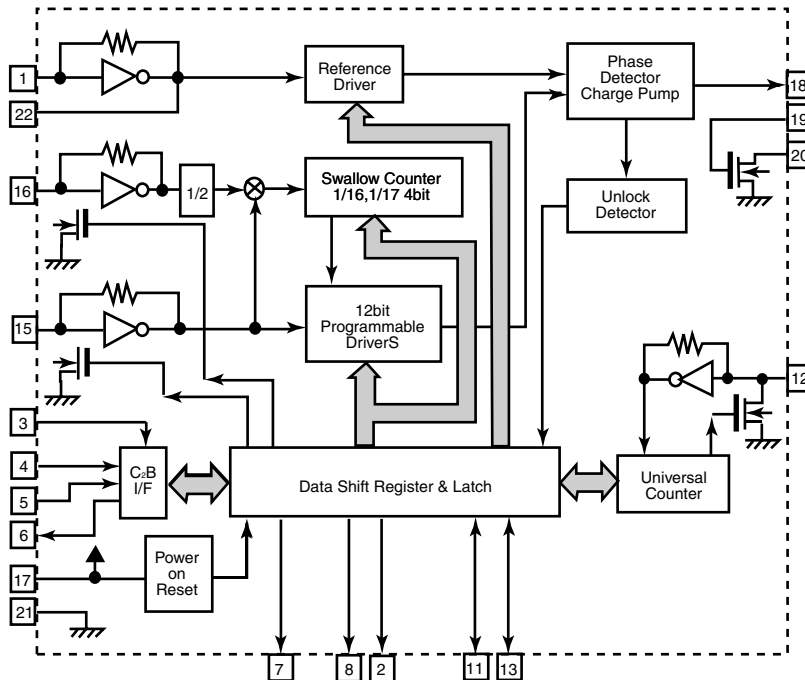

### 3. Pin function

Pin No.	Symbol	I/O	Function	Pin No.	Symbol	I/O	Function
1	XT	I	X'tal oscillator connect (75kHz)	12	IFIN	I	IF counter signal input
2	FM/AM	O	LOW:FM mode	13	IFCONT	O	IF signal output
3	CE	I	When data output/input for 4pin(input) and 6pin(output): H	14		-	Not use
4	DI	I	Input for receive the serial data from controller	15	AMIN	I	AM Local OSC signal output
5	CLOCK	I	Sync signal input use	16	FMIN	I	FM Local OSC signal input
6	DO	O	Data output for Controller Output port	17	VCC	-	Power suply(VDD=4.5-5.5V) When power ON:Reset circuit move
7	FM/ST/VCO	O	"Low": MW mode	18	PD	O	PLL charge pump output(H: Local OSC frequency Height than Reference frequency. L: Low Agreement: Height impedance)
8	AM/FM	O	Open state after the power on reset	19	LPFIN	I	Input for active lowpassfilter of PLL
9	LW	I/O	Input/output port	20	LPFOUT	O	Output for active lowpassfilter of PLL
10	MW	I/O	Input/output port	21	GND	-	Connected to GND
11	SDIN	I/O	Data input/output	22	XT	I	X'tal oscillator(75KHz)

■ LC75345M (IC302) : Electric volume

1. Terminal layout

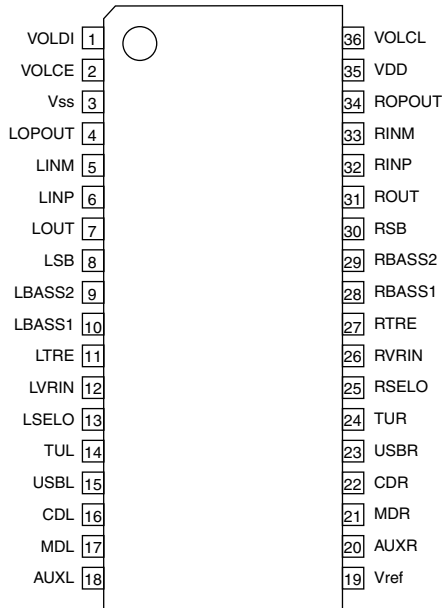

2. Pin function

Pin No.	Symbol	Function
1	VOLDI	Serial data pins and clock input pin for control
2	VOLCE	Chip enable
3	Vss	Connect to GND
4	LOPOUT	General-purpose op-amp output pin (Lch)
5	LINM	Inverted input pins of general-purpose op-amp (Lch)
6	LINP	Non-inverted input pins of general-purpose op-amp (Lch)
7	LOUT	ATT + equalizer output pin / Capacitor connection pins used to configure super bass filter (Lch)
8	LSB	Capacitor and resistor connection pins for configuring filter, used for bass band (Lch)
9	LBASS2	
10	LBASS1	
11	LTRE	Capacitor connection pins for configuring treble band filter (Lch)
12	LVRIN	Volume input pins (Lch)
13	LSELO	Input selector output pin (Lch)
14~18	AUXL,CDL, MDL,TUL,USBL	Input signal pins (Lch)
19	Vref	Connect a capacitor of few tens of $\mu\text{F}$ between Vreg and Avss (VSS) as a analog ground 0.5 X VDD voltage generator,current ripple cuntermeasures
20~24	AUXR,CDR,MDR,TUR,USBR	Input signal pins (Rch)
25	RSELO	Input selector output pin (Lch)
26	RVRIN	Volume input pins (Rch)
27	RTRE	Capacitor connection pins for configuring treble band filter (Rch)
28	RBASS1	Capacitor and resistor connection pins for configuring filter, used for bass band (Rch)
29	RBASS2	
30	RSB	
31	ROUT	ATT + equalizer output pin / Capacitor connection pins used to configure super bass filter (Rch)
32	RINP	Non-inverted input pins of general-purpose op-amp (Rch)
33	RINM	Inverted input pins of general-purpose op-amp (Lch)
34	ROPOUT	General-purpose op-amp output pin (Rch)
35	VDD	Power supply
36	VOLCL	Serial data pins and clock input pin for control

3. Block diagram

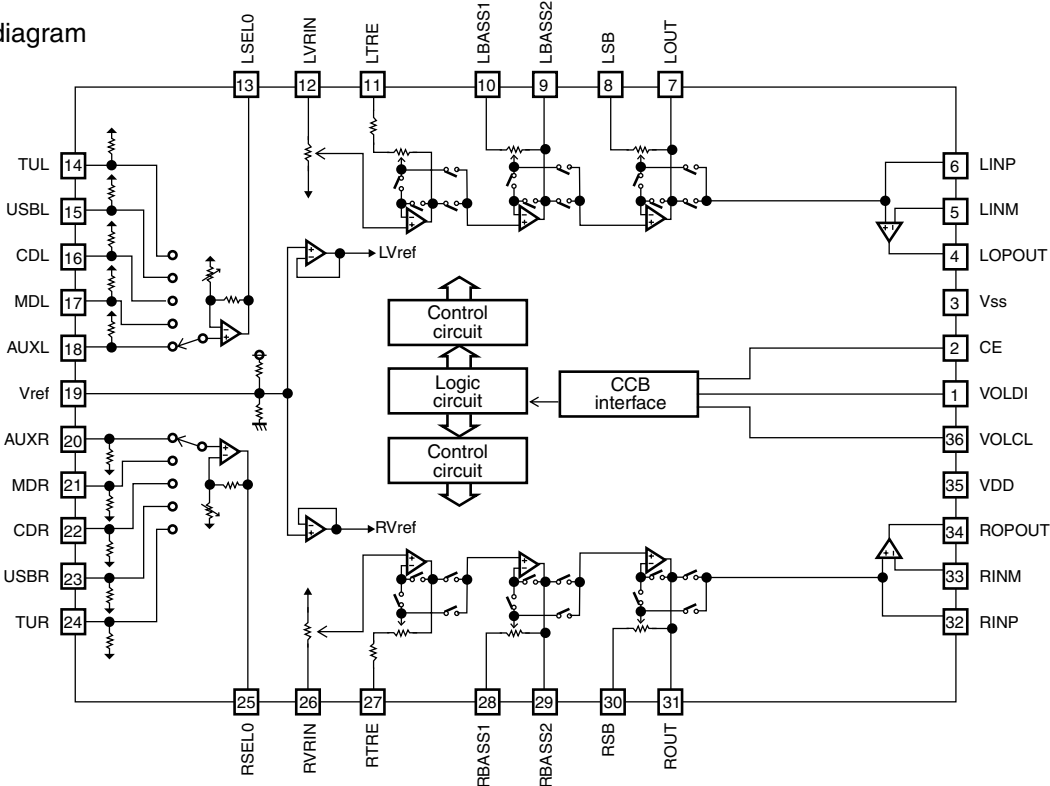



■ MIL1644SA-50T (IC390) : DRAM

1. Terminal layout

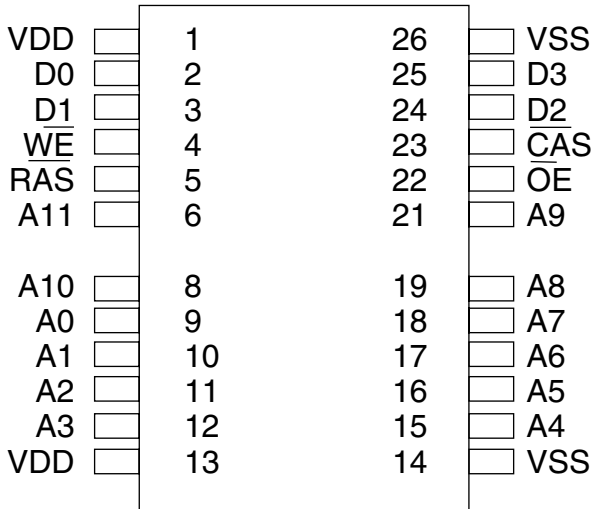

2. Pin function

Pin No.	Symbol	Function
1.13	VDD	Power supply(3.3V)
2.3.24.25	DO~D3	Data I/O
4	WE	Write enable
5	RAS	load address strobe
6.8~12. 15~19.21	AO~A11	Adress input (4K Refresh Product)
8~12. 15~19.21	AO~A10	Adress input (2K Refresh Product)
14.26	VSS	Ground
22	OE	Output enable
23	CAS	Colum adress strobe

3. Block diagram

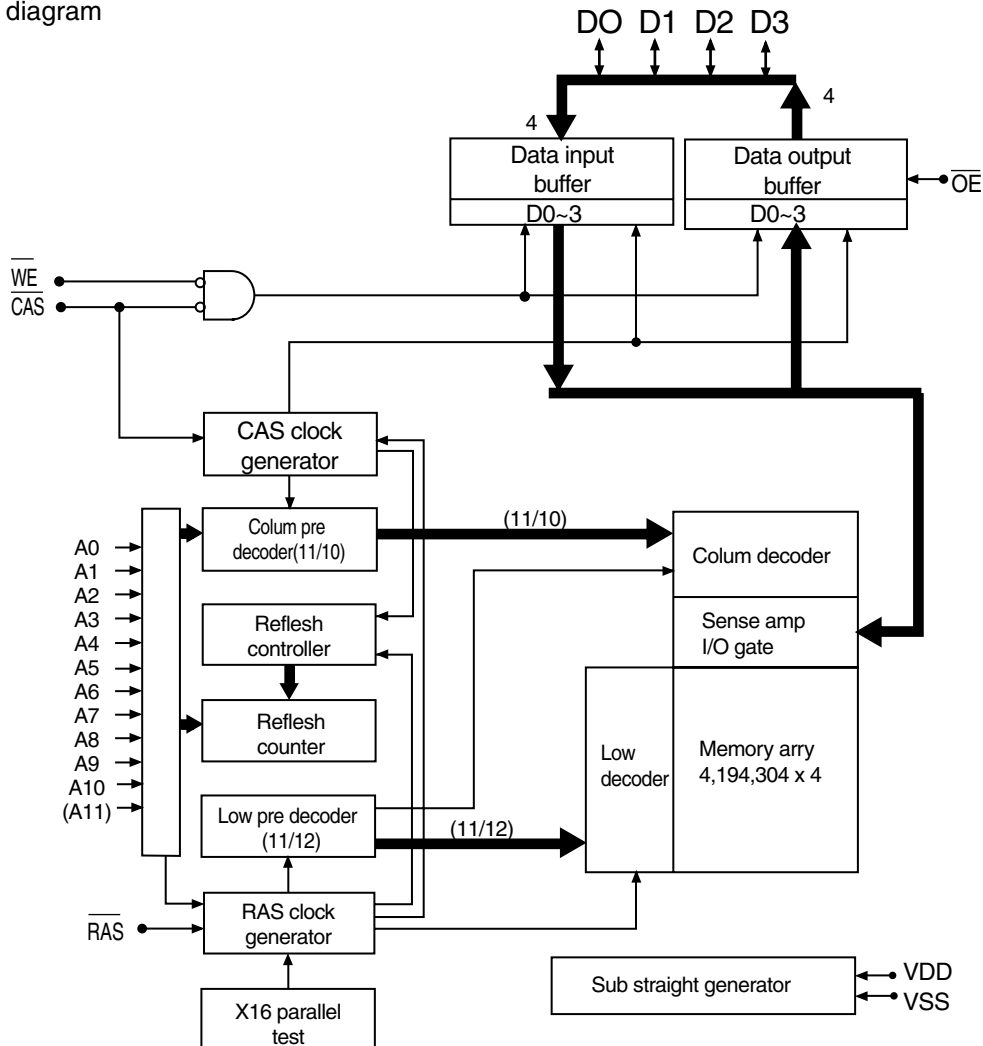

■ M63008FP (IC410) : 5ch Actuator driver

1. Terminal layout

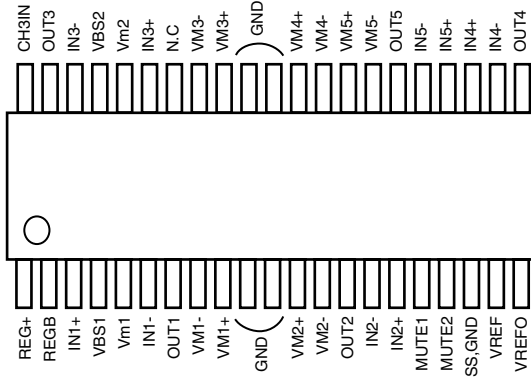

2. Block diagram

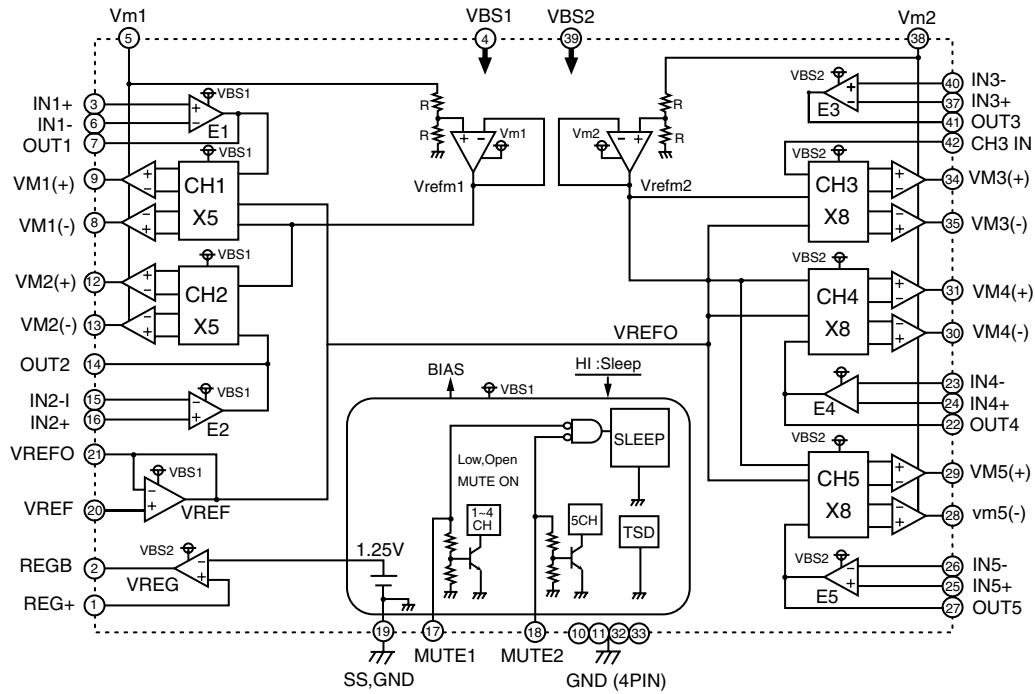

## ■ PCM2702E (IC431) : D/A converter

### 1. Terminal layout

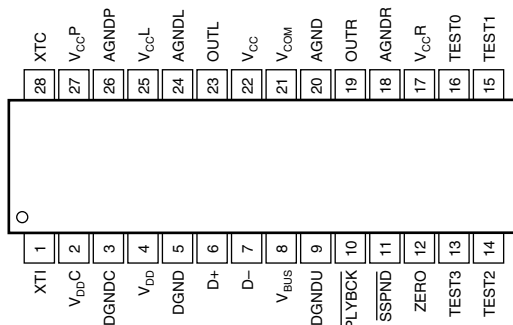

### 2. Block diagram

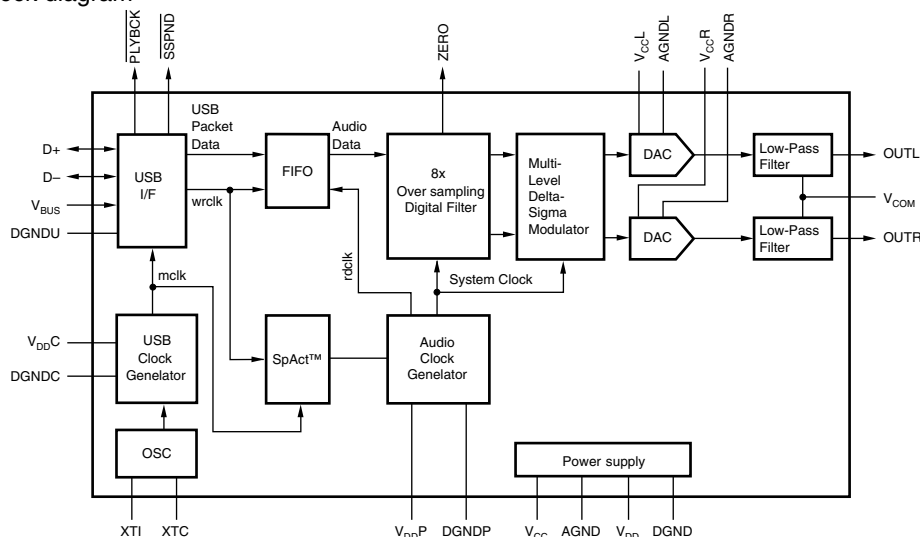

### 3. Pin function

Pin No.	Symbol	I/O	Function
1	XTI	I	Crystal oscillator input
2	V <sub>DDC</sub>	-	Digital power supply for clock generator, +3.3V
3	DGNDC	-	Digital ground for clock generator
4	V <sub>DD</sub>	-	Digital power supply, +3.3V
5	DGND	-	Digital ground
6	D+	I/O	USB differential input/output plus
7	D-	I/O	USB differential input/output minus
8	V <sub>BUS</sub>	I	USB bus power
9	DGNDU	-	Digital ground for USB transceiver
10	PLYBCK	O	Playback flag (L:playback H:idol)
11	SSPND	O	Suspend flag (L:suspend H:operational)
12	ZERO	O	Zero flag (L:normal H:zero)
13	TEST3	I	Test pin 3. Connect to digital ground
14	TEST2	I	Test pin 2. Connect to digital ground
15	TEST1	I	Test pin 1. Connect to digital ground
16	TEST0	I	Test pin 0. Connect to digital ground
17	V <sub>CCR</sub>	-	Analog supply for R-channel, +5v
18	AGNDR	-	Analog ground for R-channel
19	V <sub>OUT</sub> R	O	Analog output for R-channel
20	AGND	-	Analog ground
21	V <sub>COM</sub>	-	DC common-mode voltage for DAC
22	V <sub>CC</sub>	-	Analog supply, +5v
23	V <sub>OUT</sub> L	O	Analog output for L-channel
24	AGNDL	-	Analog ground for L-channel
25	V <sub>CC</sub> L	-	Analog supply for L-channel, +5v
26	AGNDP	-	Analog ground for PLL
27	V <sub>CC</sub> P	-	Analog supply for PLL, +5v
28	XTO	O	Crystal oscillator output

## ■ MN101C49GJJ (IC801) : System micon

### 1. Terminal layout

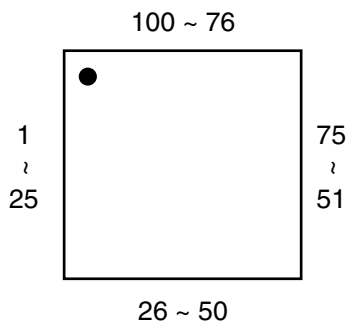

### 2. Pin function

Pin No.	Symbol	I/O	Function
1	A/D GND	-	GND for A/D
2	KEY1	I	Front control switch input 1
3	KEY2	I	Front control switch input 2
4,5		-	Not use
6	6V/5.6V SAFETY DETECT	I	6V/5.6V safety detect input
7	SW+9V SAFETY DETECT	I	SW+9V safety detect input
8		-	Not use
9	SW+8V SAFETY DETECT	I	SW+8V safety detect input
10	AD POWER	-	AD power supply
11	Vdd	-	Power supply
12	8.00(MHz)out	O	Main clock output (8MHz)
13	8.00(MHz)in	I	Main clock input (8MHz)
14	GND	-	Connect to GND
15	32kHz	O	Sub clock output (32MHz)
16	32kHz	I	Sub clock input (32MHz)
17	MNOD	-	Connect to GND
18	BEAT CUT	O	Beat cut input
19,20		-	Not use
21	KCMND	O	Serial data output
22	MSTAT	I	Status input for CD control
23	CD CLOCK	O	Command clock output for CD control
24	CD RESET	O	Reset output for CD control
25	USBON/OFF	O	USB ON/OFF control output
26	RM IN	I	Remote control signal input
27	READY	-	Not use
28	SUB CODE	-	Not use
29	CD REQUEST	I	CD request input
30		-	Not use
31	RDS CLOCK IN	-	Not use
32		-	Connect to GND
33	HARD RESET	I	System reset input
34	MD RESET	O	MD reset output
35		-	Not use
36	RDS DATA IN	-	Not use
37	CONTRAST ADJUST1	O	LCD contrast control signal output1
38	CONTRAST ADJUST2	O	LCD contrast control signal output2
39	CONTRAST ADJUST3	O	LCD contrast control signal output3
40	FAN MOTOR ON/OFF	O	FAN MOTOR ON/OFF control output

Pin No.	Symbol	I/O	Function
41	FUNCTION CD	O	CD 5V control
42	MD TX	I/O	MD control data I/O
43	MD RX	I/O	MD control data I/O
44		-	Not use
45	LCD SDA	O	LCD data output
46	LCD CS	O	LCD chip select output
47	LCD SCL	O	LCD data clock output
48	LCD RS	O	LCD reset signal output
49	LCD RESET	O	LCD reset signal output
50	TUNER DATA IN/OUT	I/O	Tuner data I/O
51	TUNER CLOCK	O	Tuner data clock input
52	TUNER STROBE	O	Tuner select signal output
53	TUNER MPX	I	Stereo indicator input
54~58		-	Not use
59	AMP SOURCE MUTE	O	System mute control output
60	AMP LINE OUT MUTE	O	Line out mute control output
61	AMP STANDBY	O	Stand by control output
62~64		-	Not use
65	AHB ON/OFF	O	Active bass ON/OFF control
66	CHIP ENABLE	O	Chip enable output for IC302
67	CLOCK	O	Clock output for IC302
68	DATA OUT	O	Serial data output for IC302
69	AMP POWER	O	Amplifier power signal output
70	AMP TR SWITCH		TR switch control
71~77		-	Not use
78	SPK PRT	O	
79	VOL KEY LED	O	Volume key LED control
80	AMP INH		Obstruction signal control
81	MD REC IND	-	Not use
82	AMP BAND-0(CS)		Not use
83	AMP BAND-1(CS)		Not use
84	STANDBY IND(RE D)	O	Stand by LED control output (RED)
85	STANDBY IND(GREEN)	O	Stand by LED control output (GREEN)
86	TUNER power	O	Tuner power signal control
87~94		-	Not use
95	DAVss	-	Connect to GND
96~98		-	Not use
99	BACK LIGHT	O	Back light ON/OFF control output
100	DAVdd	-	Connect to power supply

■ MN662790RSC (IC651) : Digital servo & digital signal prosessor

1. Terminal layout

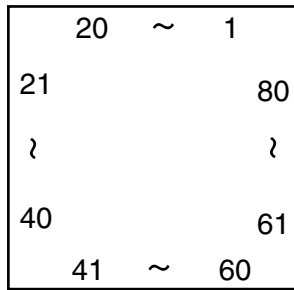

2. Pin function

Pin No.	Symbol	I/O	Function	Pin No.	Symbol	I/O	Function
1	BCLK	O	Bit clock output for SRDATA	41	PLL2		
2	LRCK	O	LR signal separation output	42	DSLBD	-	Not use
3	SRDATA	O	Serial data output	43	WVEL	-	Not use
4	DVDD1	-	Power supply for digital circuit	44	ARF	I	RF signal input
5	DVSS1	-	GND for digital circuit	45	IREF	I	Reference current input
6	TX	O	Digital audio ineterface output	46	DRF	I	Bias pin for DSL
7	MCLK	I	Micro computer command clock signal input	47	DSL2	I/O	Loop filter pin for DSL
8	MDATA	I	Micro computer command data input	48	PLL	I/O	Loop filter pin for PLL
9	MLD	I	Micro computer command load signal input (L:Load)	49	VCOF	I/O	Loop filter pin for VCO
10	SENSE	-	Not use	50	AVDD2	-	Power supply for analog circuit
11	FLOCK	-	Not use	51	AVSS2	-	GND for analog circuit
12	TLOCK	-	Not use	52	EFM	-	Not use
13	BLKCK	O	Sub code block signal output	53	DSL	O	DSL balance output
14	SQCK	I	External clock input for sub code Q register input	54	VCOF2	I/O	Loop filter pin for Digital servo VCO
15	SUBQ	O	Sub code Qdata output	55	SUBC	-	Not use
16	DMUTE	I	Muting input (H:Mute)	56	SBCK	-	Not use
17	STAT	O	Status signal input	57	VSS	-	GND for crystal oscillation circuit
18	DSP-RST	I	Reset signal input (L:Reset)	58	X1	I	Input for crystal oscillation circuit (f=16.9344MHz)
19	SMCK	-	Not use	59	X2	O	Output for crystal oscillation circuit (f=16.9344MHz)
20	CSEL	I		60	VDD	-	Power supply for crystal oscillation circuit
21	TEST2	-	Not use	61	BYTCK	-	Not use
22	TVD	O	Traverse drive output	62	LD		
23	PC	-	Not use	63	GAIN		
24	ECM	O	Spindle motor drive signal (Enforced mode output)	64	IPFLAG	-	Not use
25	ECS	O	Spindle motor drive signal (Servo error signal output)	65	FLAG	O	Flag signal output
26	VDETMON	-	Not use	66	CLVS	-	Not use
27	TRD	O	Tracking drive output	67	CRC	-	Not use
28	FOD	O	Focus drive output	68	DEMPH	-	Not use
29	VREF	I	Reference voltage for D/A output block	69	RESY	-	Not use
30	FBAL	O	Focus balance adjust signal output	70	IOSEL	I	Mode select pin , Connect to DVDD1 (H fix)
31	TBAL	O	Tracking balance adjust signal output	71	TEST	I	Test pin ,Connect to DVDD1 (H fix)
32	FE	I	Focus error signal input (Analog input)	72	AVDD1	-	Power supply for analog circuit
33	TE	I	Tracking error signal input (Analog input)	73	OUTL	O	L-channel audio output
34	RF ENV	I	RF envelope signal input (analog input)	74	AVSS1	-	GND for analog circuit
35	TEST3	I	Connect to GND	75	OUTR	O	R-channel audio output
36	OFT	I	Off track signal input (H:Off track)	76	DQSY		
37	TRCRS	I	Track crosssignal input	77	Vcc5V	-	Connect to power supply
38	RFDET	I	RF detect signal input (L:Detect)	78	PSEL	I	IOSEL=H , Test pin , Connect to GND ( L fix)
39	BDO	I	Drop out signal input (H:Drop out)	79	MSEL	-	IOSEL=H , SMCK output , Frequency select pin
40	LDON	-	Not use	80	SSEL	I	IOSEL=H , SMCK output , SUBQ output mode select pin

### ■ XC62HR3502P (IC291) : Regulator

1. Terminal layout

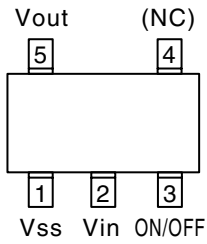

2. Block diagram

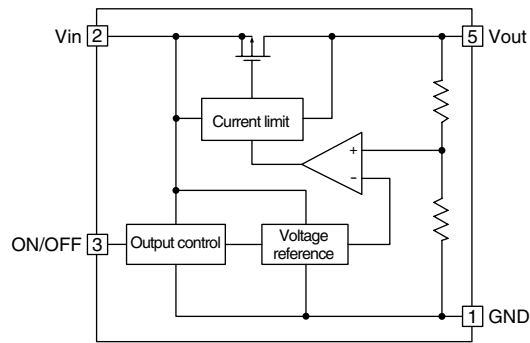

3. Pin function

Pin No.	Symbol	Function
1	VSS	GND
2	Vin	Power supply input
3	ON/OFF	ON/OFF control
4	(NC)	Not use
5	Vout	Regulator output

### ■ XC62ER3602M (IC400) : Regulator

1. Terminal layout

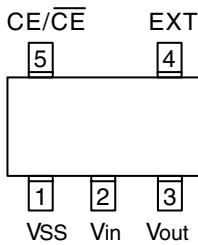

2. Block diagram

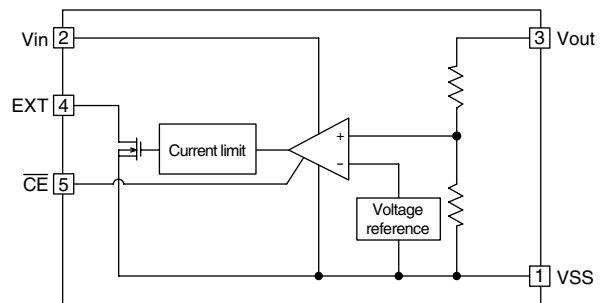

3. Pin function

Pin No.	Symbol	Function
1	VSS	GND
2	Vin	Power supply input
3	Vout	Regulator output
4	EXT	Base current control
5	CE/CE	Chip enable

## ■ UPD780024AGKB21 (IC251) : Unit micon

### 1. Pin layout

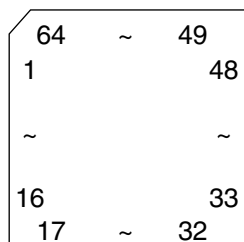

### 2. Pin function (1/2)

Pin No.	Symbol	I/O	Function
1	-	-	Connect to GND
2	-	-	Non connect
3	MCS	O	Synchronization/asynchronous system
4	MRDY	-	Reday signal input terminal
5	CDINDEX	O	
6	CDEMP	O	CD emphasis
7	CDTNO	I	CD track No. change
8	CDCOPY	O	CD copy right or wrong
9	VSSO	-	Connect to GND
10	VDDO	-	Power supply
11	-	-	Non connect
12	-	-	Non connect
13	-	-	Non connect
14	MUTE	I	Mute signal input
15	SUBQ	I	Sub Q data input
16	-	-	Non connect
17	SQCK	O	Sub Q clock output
18	KCMND	I	Reset signal input
19	MSTAT	O	Not use
20	KCLK	I	Command data clock input
21	RXDO	I	(Command in)
22	TXDO	O	(Status out)
23	-	-	Connect to GND
24	VDD1	-	Power supply
25	AVSS2	-	Connect to GND
26	KEY1	I	Key1 signal from running jig
27	KEY2	I	Key2 signal from running jig
28	PCHK	I	
29	-	-	Connect to GND
30	-	-	Connect to GND
31	/OPEN	I	
32	/REST	I	



## 2. Pin function (2/2)

Pin No.	Symbol	I/O	Function
33		-	Connect to GND
34	AVREF	I	Reference power supply voltage
35	AVDD	-	Power supply
36	/RESET	I	CD reset signal input
37	XT2	-	Non connect
38	XT1	-	Connect to power supply
39	IC	I	Not use (For flash micon)
40	X2	O	X'tal osc output
41	X1	I	X'tal osc input
42	VSS1	-	Connect to GND
43	FLAG	O	FLAG for C1 error
44	BLKCK	O	Sub Q block signal output
45	/RFDET		
46	EQX2		
47	EQX4		
48	VCOX4		
49	OPEN		
50	/CLOSE		
51	IREFX4		
52	-	-	Non connect
53	/RESET	O	Reset signal output
54	STAT	I	Status signal input
55	/DMUTE	I	Digital mute signal input
56	/P.ON	I	Power on signal input
57	MLD	I	Command load signal input
58	MDATA	I	Command data input
59	MCLK	I	Command clock input
60	CLKSW		
61	JIG	-	Non connect
62	JIG	-	Non connect
63	JIG	-	Non connect
64	JIG	-	Connect to GND

■ UPD784217AGC139 (IC500) : MD control micon

1. Terminal layout

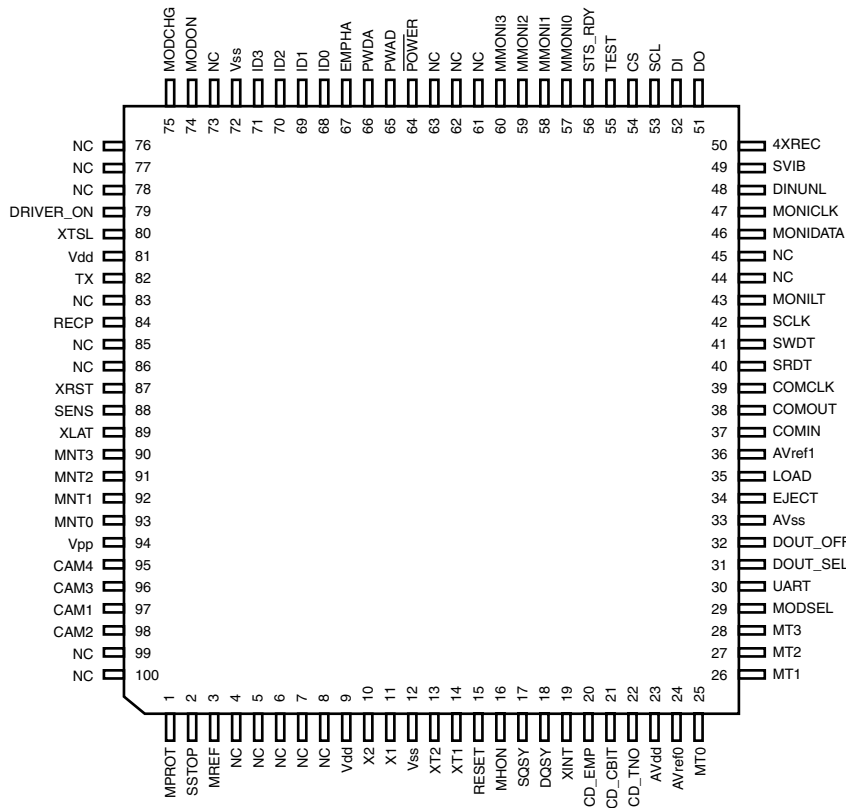

2. Pin function

Pin No.	Symbol	I/O	Function
1	MPROT	I	Write protect switch input
2	SSTOP	I	SLED rest position detect input
3	MREF	I	Disc hole detect switch(Reflectivity detection input)
4 ~8	NC	-	Not use
9	Vdd	-	Power supply
10	X2	-	Oscillation terminal (12MHz)
11	X1	-	Oscillation terminal (12MHz)
12	Vss	-	Connect to GND
13	XT2	-	Not use
14	XT1	-	Connect to GND
15	RESET	I	Reset input
16	MHOM	O	Magnetic head driver ON/OFF L:REC
17	SQSY	I	Sub code Q/A dip syne
18	DQSY	I	"Digital in of U-bit ,S-code Q sink input terminal"
19	XINT	I	Interrupter requier
20	CD_EMP	I	CD emphasis input
21	CD_CBIT		
22	CD_TNO		
23	Avdd	-	Power supply (Analog)
24	AVref0	-	Connect to GND
25 ~28	MT0 ~ MT3	-	Connect to GND
29	MODSEL	I	Mode select input
30	UART	I	External commication style select terminal H:UART L:Four line style
31	DOUT_SEL	I	Digital out select terminal H:DIN throw output L:FS convert output
32	DOUT_OFF	I	Digital out select terminal H:OFF L:OFF

Pin No.	Symbol	I/O	Function
33	Avss	-	Connect to GND
34	EJECT	O	Motor driver control signal output H:EJECT L:LOAD
35	LOAD	O	Motor driver control signal output H:LOAD L:EJECT
36	AVref1	-	Connect to power supply
37	COMIN		
38	COMOUT		
39	COMCLK	I	Clock input from host
40	SRDT	I	Data input
41	SWDT	O	Data output
42	SCLK	O	Serial clock output
43	MONILT	-	Not use
44	NC	-	Not use
45	NC	-	Not use
46	MONIDATA	-	Not use
47	MONICLK	-	Not use
48	DINUNL	-	Not use
49	SVIB	O	Sled electrical Vibration signal
50	AXREC		
51	DO	O	Serial data output for EEPROM
52	DI	I	Serial data input for EEPROM
53	SCL	O	Clock output for EEPROM
54	CS	O	Chip select for EEPROM
55	TEST	-	Test terminal
56	STS_RDY	-	Not use
57 ~60	MMONI0 ~3	I	Test terminal
61 ~63	NC	-	Not use
64	POWER	O	Power ON/OFF control signal terminal H:Power ON
65	PWAD	O	AD power control output
66	PWDA	O	DA power control output
67	EMPHA	O	Emphasis control output
68 ~71	ID0 ~3	-	Connect to GND
72	Vss	-	Connect to GND
73	NC	-	Not use
74	MODON	O	High frequency ON/OFF output
75	MODCHG	O	High frequency power select output
76 ~78	NC	-	Not use
79	DRIVER_ON		
80	XTSL	O	Connect to XTSL terminal for IC350
81	Vdd	-	Power supply
82	TX	O	Write data output
83	NC	-	Not use
84	RECP	O	Connect to RECP terminal for IC350
85	NC	-	Not use
86	NC	-	Not use
87	XRST	O	LSI reset output
88	SENS	I	Monitor input
89	XLAT	O	Connect to XLAT terminal for IC350
90 ~93	MNT3 ~0	I	LSI monitor signal
94	Vpp		
95 ~98	CAM4 ~1	I	Mechanism position detect input
99	NC	-	Not use
100	NC	-	Not use

■ LA72723(IC3): RDS demodulation

1. Terminal layout

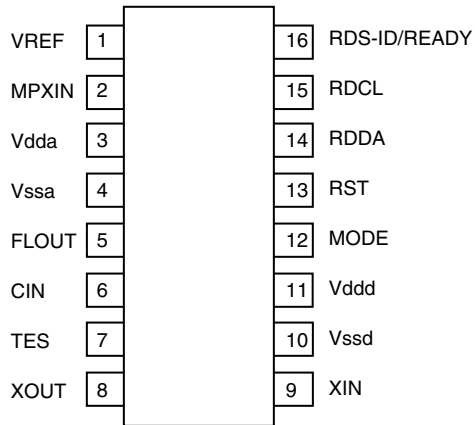

2. Block Diagram

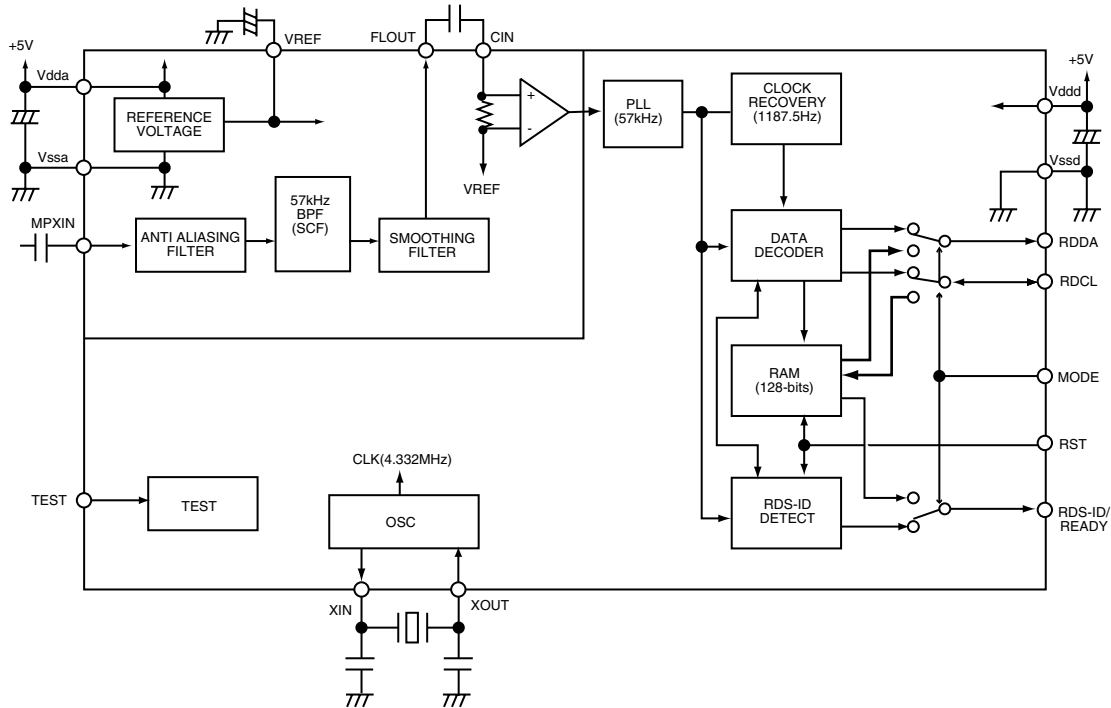



**VICTOR COMPANY OF JAPAN, LIMITED**

AUDIO & COMMUNICATION BUSINESS DIVISION

PERSONAL & MOBILE NETWORK BUSINESS UNIT. 10-1,1Chome,Ohwatari-machi,maebashi-city,371-8543,Japan